

LOTUS EUROPA

Workshop Manual

LOTUS CARS LIMITED

Norwich Norfolk, Nor. 92W England

Telephone: Wymohdham 3411. Cables: Lotus. NORWICH Telex: 97401

Part No A046T0327Z

August 1972 ©



NOTE: Lotus policy is one of continuous product improvement and the right is reserved to alter specifications at any time without prior notice.

Whilst reasonable efforts have been made to ensure that at the time of publishing this manual is correct, the descriptions and illustrations appearing are not binding.

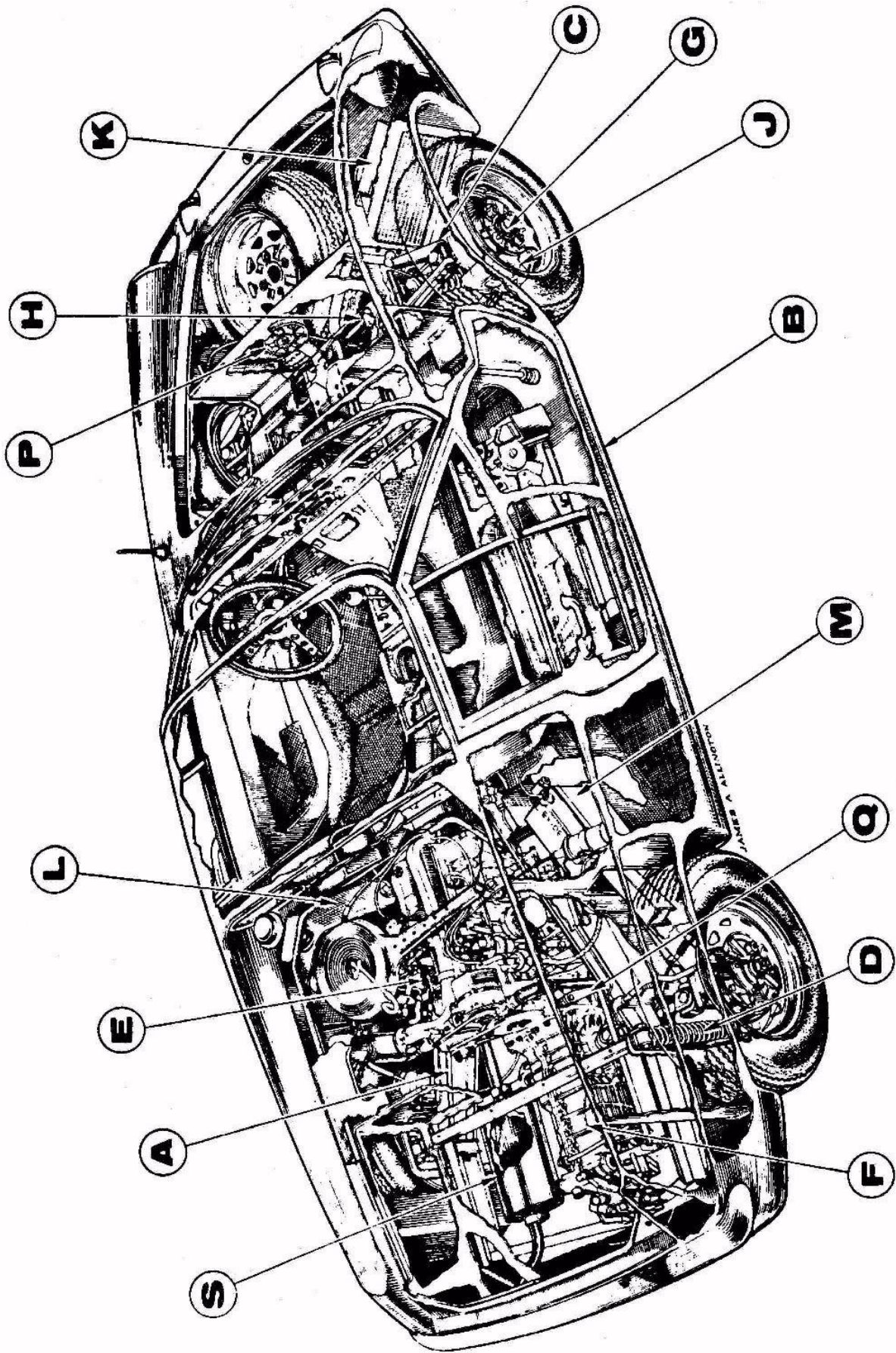

CONTENTS

Technical Data	Page 9
Chassis	A
Body	B
Front Suspension	C
Rear Suspension	D
Engine	E
Transmission	F
Hubs, Wheels and Tyres	G
Steering	H
Brakes	J
Cooling System	K
Fuel System	L
Electrical Equipment	M
Lubrication and Maintenance	O
Heating and Ventilation	P
Clutch	Q
Exhaust System	S

INTRODUCTION

This Workshop Manual, which is in loose-leaf form for easy amendment, has been compiled to assist Lotus Dealers throughout the world in the efficient repair and maintenance of the Lotus Europa models.

The various units and systems of the vehicle are dealt with in sections which are listed on page 5, each being distinguished by a reference letter, this letter being the same as is used in other service publications (i.e., A -- chassis in Parts Lists and in the Labour Schedule). Each section thus referred to opens with a contents page so that any particular operation can be easily located.

Service Information

Design changes, product improvements or changes in procedure subsequent to the publishing of this manual are given in Service/Parts Bulletins, which are issued regularly to all authorised Lotus Dealers. Should existing instructions be affected or additional information be needed, new pages to this manual will be issued to Lotus Dealers when convenient.

To ensure the manual is kept up-to-date, write the Bulletin number, the section and page number it affects and the subject matter in the space provided on page 8.

Technical Data

Comprehensive information regarding dimensions, tolerances, weights and torque loading figures of all nuts and bolts are given on page commencing 9.

Recommended Lubrication and Maintenance

Attention is drawn to Section 'O' of this manual for the Factory approved recommended lubricants and intervals of Periodical Maintenance.

Frost Precautions

Attention is drawn to the recommendations given in Section 'K' (Cooling System) of this manual on the importance of taking proper precautions against damage by frost.

Paint and Body Protection

When work is carried out on any part of the car where damage could be caused to the paint and body, i.e. working on the engine, or removing the windscreen, it is recommended that body protection covers be used.

SECTION CHECK LIST

The number of pages in each Section is correct at: November 1971.

<u>Section</u>	<u>Description</u>	<u>Number of Pages</u>
	TECHNICAL DATA	20
A	CHASSIS	9
B	BODY	40
C	FRONT SUSPENSION	18
D	REAR SUSPENSION	13
E	ENGINE	63
F	TRANSMISSION	45
G	WHEELS, HUBS AND TYRES	9
H	STEERING	13
J	BRAKING SYSTEM	22
K	COOLING SYSTEM	10
L	FUEL SYSTEM	34
M	ELECTRICAL EQUIPMENT	56
O	LUBRICATIONS AND MAINTENANCE	13
P	HEATING AND VENTILATION	5
Q	CLUTCH	10
S	EXHAUST SYSTEM	4

SERVICE BULLETIN RECORD

To ensure that the information contained in the manual is up-to-date, Lotus Dealers are asked, when they receive them, to record in the columns below, the bulletin numbers with their subjects and the section and page number affected.

If reference is then made to these columns before turning to the appropriate section, it will be seen immediately if any amendment subsequent to the publishing of the manual is applicable.

Bulletin Number	Date	Section	Page No.	Subject

VEHICLE IDENTIFICATION (Chassis Numbering)

Commencing at the 1st of January 1970, a new format has been used for Vehicle Identification.

An example of a new chassis number is given below, together with the full identification breakdown.

7001.010001P Both chassis and body numbers being the same

7001	Denotes year and month of manufacture (1970, January)
01	Denotes the production batch
0001	Denotes the chassis number
P	Denotes the model

As there are at present 16 different model types, the following codes will be used for model identification.

Elan STD	Coupe	G. Britain & N. Ireland	A
Elan STD	Coupe	Export	B
Elan STD	Convertible	G. Britain & N. Ireland	C
Elan STD	Convertible	Export	D
Elan S/E	Coupe	G. Britain & N. Ireland	E
Elan S/E	Coupe	Export	F
Elan S/E	Convertible	G. Britain & N. Ireland	G
Elan S/E	Convertible	Export	H
Elan Federal	Coupe	Export	J
Elan Federal	Convertible	Export	K
Elan +2'S'		G. Britain & N. Ireland	L
Elan +2'S'		Export	M
Elan +2'S' Federal		Export	N
Europa		G. Britain & N. Ireland	P
Europa		Export	Q
Europa Federal		Export	R

TECHNICAL DATA

INDEX

<u>Description</u>	<u>Page</u>
Dimensions	9
Capacities	9
Engine:	
General	9
Performance	9
Cylinder Head	10
Camshaft	10
Crankshaft	11
Connecting Rod	11
Gudgeon (Piston) Pin	11
Piston	11
Lubrication	12
Fuel System:	
Pump	12
Air Cleaner	12
Carburettors	12
Ignition System:	
Ignition Timing	13
Sparking Plugs	13
Distributor	13
Cooling System	13
Clutch	14
Transmission:	
Bearings	14
Adjustment	14
Ratios	14
Speedometer Gears	14
Overall Ratios	14
Front Suspension	15
Steering	15
Rear Suspension	15
Brakes	15
Wheels & Tyres	16
Electrical Equipment:	
Battery	16
Fuses	16
Alternator	16
Starter	16
Lamp Bulbs	17
Additional Information:	
Ignition Distributor (Exhaust Emission)	17
Torque Loading Figures	18

TECHNICAL DATA

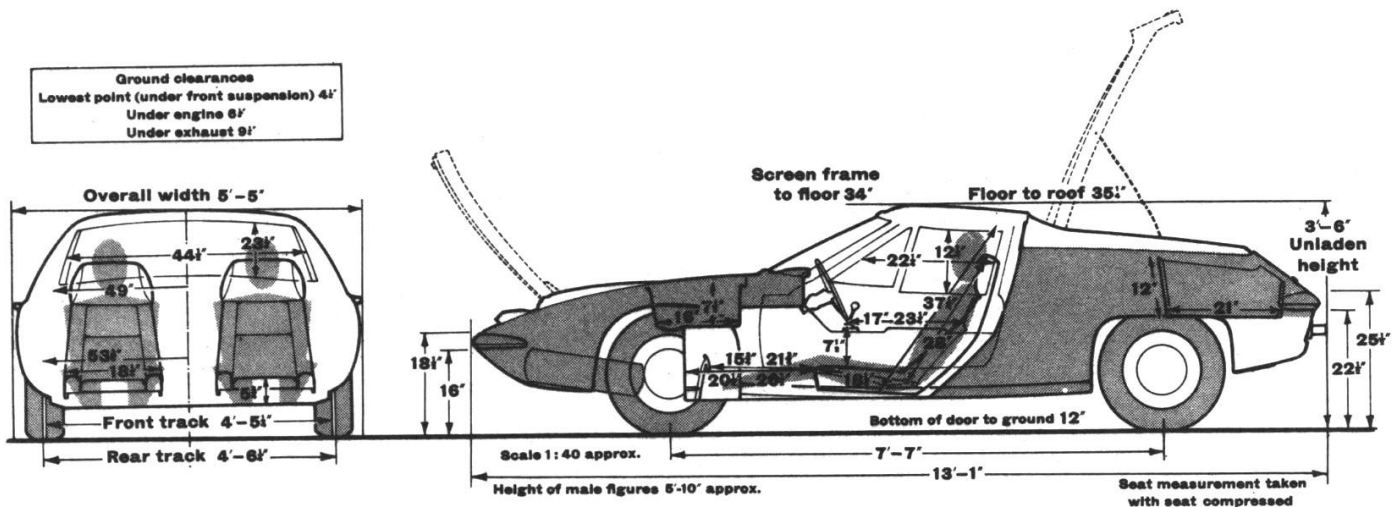

Above image from Motor Magazine 6 Sep 1969. [2]

DIMENSIONS

Wheelbase		91 in. (231.1 cm.)
Track (at wheel hub)	- Front	53 in. (134.6 cm.)
	- Rear	53 in. (134.6 cm.)
Overall	- Length	157 1/4 in. (399.4 cm.)
	- Width	64 1/2 in. (163.8 cm.)
	- Height	42 1/2 in. (107.9 cm.)
Ground clearance (design)		6 1/2 in. (16.5 cm.)
Turning circle		44 ft. (13.4 m.)
Kerb weight (unladen)	- Series I	1350 lbs. (612 kg.)
	- Series II	1566 lbs. (710 kg.)

CAPACITIES

Engine sump (including filter)	7 1/2 pints (4 litres; 9 U.S. pints)
Transmission	3 pints (1.75 litres; 3.6 U.S. pints)
Coolant (with heater)	18 pints (10.3 litres; 21.6 U.S. pints)
Fuel	6 gallons (27 litres; 7.2 U.S. gallons)

ENGINE

General

Number of cylinders	4
Capacity	- Non Exhaust Emission 89.7 cu. in. (1470 cc.) - Exhaust Emission 95.5 cu. in. (1565 cc.)
Stroke	- Non Exhaust Emission 3.189 in. (81 mm.) - Exhaust Emission 3.307 in. (84 mm.)
Bore	- Non Exhaust Emission 2.992 in. (76 mm.) - Exhaust Emission 3.032 in. (77 mm.)
Compression ratio (all)	10.25:1

PERFORMANCE

Max. BHP @ r.p.m.	- Non Exhaust Emission 82 @ 6,000 - Exhaust Emission 80 @ 6,000
Max. Torque @ r.p.m. (all)	79 lbs.ft. (10.92 kg.m.) @ 4,000
Road speed per 1,000 r.p.m. in top gear	17.7 m.p.h. (28.5 k.p.h.)

Cylinder Head

Material		Aluminium
Valve timing	- Inlet opens	35° B.T.D.C.
	- Inlet closes	65° A.B.D.C.
	- Exhaust opens	65° B.B.D.C.
	- Exhaust closes	35° A.T.D.C.
Angle of valve seats and faces		45°
Valves - Head diameter	- Inlet	1.476 in. (37.5 mm.)
	- Exhaust	1.220 in. (31 mm.)
- Stem diameter	- Inlet	.315 in. (8 mm.)
	- Exhaust	.315 in. (8 mm.)
- Stem clearance in guide	- Inlet	.0010/.0018 in. (.025/.045 mm.)
	- Exhaust	.0016/.0024 in. (.040/.060 mm.)
- Clearance (cold)	- Inlet	.008 in. (.20 mm.)
	- Exhaust	.010 in. (.25 mm.)
Valve springs - Type		Helical, double
- Free length	- Inner	1.492 in. (37.89 mm.)
	- Outer	1.929 in. (49 mm.)
Valve guides - Length	- Inlet	1.968 in. (50 mm.)
	- Exhaust	1.968 in. (50 mm.)
- Fitted height above head		.472 in. (12 mm.)

Camshaft

Number and type of bearings		4, white metal
Journal diameter		1.653 in. (42 mm.)
Bearing running clearance		.001/.0029 in. (.025/.075 mm.)
End float		.002/.0047 in. (.05/. 12 mm.)
Tappets	- Standard	.473 in. (12 mm.)
	- Oversize	.480 in. (12.2 mm.)
Drive	- Type	Chain
	- Number of pitches	72
	- Length (of pitch)	.375 in. (9.525 mm.)
	- Width (of pitch)	.225 in. (5.72 mm.)

Crankshaft

Diameter	- Main journals	2.158 in. (54.8 mm.)
	- Crankpin	1.890 in. (48 mm.)
End float	- Dimension	.002/.009 in. (.05/.23 mm.)
	- Controlled by	Thrust washers on centre main bearing
Bearings	- Number	5
	- Type	Aluminium lead, thin wall
	- Running clearance	.0015/.0031 in. (.038/.079 mm.)
Maximum undersize for regrind		.02 in, (.50 mm.)

Connecting Rod

Type		'H' section
Material		Steel forging
Distance between centres		5.363 in. (13.62 cm.)
Bearings	- Type	Aluminium Lead, thin wall
	- Running clearance	.0007/.0028 in. (.017/.058 mm.) [1]
	- Side clearance	.012/.022 in. (.310/.572 mm.)

Gudgeon (Piston) Pin

Location		Force fit in connecting rod
Diameter		.787 in. (20 ram.)
Class of fit	- In piston	.0001/.0003 in. (.003/.009 mm.)
	- In connecting rod	.0007/.0015 in. (.020/.041 mm.)

Piston

Type		Solid skirt
Material		Aluminium
No. of rings	- Compression	2
	- Oil control	1
Piston clearance in cylinder liner		Matched piston and liner sets
Piston rings:		
Gap in liner (fitted)	- Compression	.009/.015 in. (.25/.40mm.)
	- Oil control	.009/.015 in. (.25/.40 mm.)
Groove clearance	- Compression	.0019/.0029 in. (.05/.075 mm.)
	- Oil control	.0005/.0023 in. (.015/.06 mm.)
Width	- Compression	.078 in. (2 mm.)
	- Oil control	.157 in. (4 mm.)

Lubrication System

Pump - Type	Eccentric rotor
- Drive	Skewgear from camshaft
- Inner to outer rotor clearance	See Section 'E' (Engine)
Normal pressure (hot) @ 2,000 r.p.m.	30 lbs.in.sq. (2. kg.cm.sq.)
Filter	Full - flow ('throw away' canister)

FUEL SYSTEM

Pump operation	Mechanical
Air cleaner type	Paper element (dry)
Choke control	Manual
Carburetter - Non Exhaust Emission:	
Type	Solex 35 DIDS A 2 (twin choke)
Slow running speed	900/1,000 r.p.m.
	<u>Primary</u> <u>Secondary</u>
Choke	26 26
Main jet	145 140
Air correction jet	135 150
Accelerator pump jet	40 Nil
Power jet	Nil 80/270
Inner venturi	28 32

Carburetter - Exhaust Emission:

Type	Solex 26 - 32 DIDS A 5 (twin choke)
Slow running speed	1,000 +- 50 r.p.m.
	<u>Primary</u> <u>Secondary</u>
Choke	23.5 27
Main jet	120 142.5
Air correction jet	125 125
Slow running jet	60 95

IGNITION SYSTEM

Type	Coil and distributor
Firing order	1,3,4,2
No. 1 cylinder	Nearest to clutch
Ignition advance control	Centrifugal

Ignition timing (static)

Non Exhaust Emission

4° B.T.D.C.

Exhaust Emission

T.D.C.

Coil

Ducellier 2765 A

Sparking plugs - Type*

Marchal 34 HS

- Gap

.023 in. (.584 mm.)

*Alternatively, Champion N4, Champion NTY or Autolite AG22 may be used in all engines with a points gap of .023 in. (.584 mm.).

Distributor

Type

Ducellier 4 cylinder

Drive

Skew gear from camshaft

Direction of rotation (from above)

Anti-clockwise

Contact breaker gap

.016/.019 in. (.40/.50 mm.)

Cam dwell angle

61° +- 3°

Firing angles

0°, 90°, 180°, 270° +- 1°

Centrifugal advance (Non Exhaust Emission):

Distributor

Distributor

r.p.m.

degrees B.T.D.C.

Below 550

No advance

920

7.8

1,000

8.0

2,000

13.0

3,000

18.0

Vacuum advance (Non Exhaust Emission):

Distributor

Vacuum

degrees B.T.D.C.

Hg. inches

1.5

3.937

4.6

7.874

6.5

11.811

7.0

15.748

COOLING SYSTEM

Type

Centrifugal pump and fan

Radiator cap relief valve

7 lbs .in .sq. (.49 kg.cm .sq .)

Thermostat nominal opening temperature

68° C.

Water pump belt tension (at longest run)

09375/.15625 in. (2.3812./3.9687 mm.)

Alternator belt tension (at longest run)

.28125/.375 in. (7.1437/9.525 mm.)

CLUTCH

Make and type	Ferodo 200 D, diaphragm spring
Operation	Cable
Driven plate diameter	7.875 in. (20 cm.)
Clutch assembly adjustment	See Section 'Q' (Clutch)
Free movement at withdrawal lever	.078/.125 in. (2/3 mm.)

TRANSMISSION

Type	4 forward speeds, all synchromesh and reverse
Bearings	Taper rollers
- Mainshaft	
- Secondary gear cluster	Taper rollers
Bearings adjustment	See Section 'F' (Transmission)
Gear ratios	
- Top	1.03:1
-3rd.	1.48:1
-2nd.	2.25:1
- 1st.	3.61:1
-Reverse	3.08:1

Final drive:

Type	Hypoid gear J
Bearings	Taper rollers
- Pinion	
- Diff./crown wheel assy.	Taper rollers

Bearings adjustment:

Pinion bearing pre-load	See Section 'F' (Transmission)
Crown wheel/pinion backlash	.005/.010 in. (.127/.254 mm.)

Number of teeth	
- Crown wheel	32
- Pinion	9

Final drive ratio	3.56:1
-------------------	--------

Speedometer gears:	<u>Driving Gear</u>	<u>Driven Gear</u>
	46 F 6049, 6 teeth	46 F 6108, 12 teeth
	Pink	Blue

Overall ratios	
- Top	3.666:1
- 3rd.	5.268:1
- 2nd.	8.010:1
- 1st.	12.851:1
- Reverse	10.964:1

FRONT SUSPENSION

Type	Independent
Spring - Number of coils	17
- Wire diameter	.348 in. (8.83 mm.)
- Length - Free	12.75 in. (32.38 cm.)
- Fitted	7.75 in. (19.68 cm.)
- Rate	100 lbs.in. (1.15 kg.m.)
Front hub end float	.002/.004 in. (.05/.10 mm.)

STEERING

Type	Rack and pinion
Steering angles - Camber	0° to +- 30'
- Castor	3° +- 30'
- Swivel pin (kpi)	9° +- 30'
Toe - in	3/16 in. (4.76 mm.) to 1/16 in. (1.6 mm.)
Condition for checking toe - in	6t in. (16.5 cm.) ground clearance at bottom of chassis closing plate.

REAR SUSPENSION

Type	Independent
Spring - Number of coils	19½
- Wire diameter	.329 in. (8.35 mm.)
- Length - Free	16.2 in. (41.15 cm.)
- Fitted	10.4 in. (26.42 cm.)
- Rate	72 lbs. in. (.83 kg. m.)
Wheel camber	0° to 2° Negative
Toe - in	3/16 in. (4.76 mm.) to Zero

BRAKES

Make and type	Girling hydraulic (servo optional)
Front brakes - Disc diameter	9.75 in. (24.76 cm.)
- Pads material	Ferodo DS.31
Total disc run out	.004 in. (.10 mm.)
Rear brakes - Drum dia. and width	8 in. (20.3 cm.) x 1.25 in. (3.175 cm.) [3]
- Lining material	Don. 242
Handbrake type	Mechanical, on rear only

WHEELS AND TYRES

Wheel	- Type	Pressed steel bolt on
	- Size	4½ J
Tyres*	- Type	Firestone F.100 tubeless or, Dunlop SP Sport with tubes.
Tyres*	- Size	155 x 13
	*If inner tubes are fitted, it is essential that these are of the correct type for radial ply tyres.	
Tyres	- Pressure (cold):	At speeds BELOW At sustained speeds
		100 mph (160 kph) ABOVE 100 mph (160 kph)
	- Front	18 lbs.in.sq. 24 lbs.in.sq. (1.27 kg.cm.sq.) (1.69 kg.cm.sq.)
	- Rear	28 lbs.in.sq. 34 lbs.in.sq. (1.97 kg.cm.sq.) (2.39 kg.cm.sq.)

ELECTRICAL EQUIPMENT

Battery

Type	Exide 6 VTA 29 L
Capacity @ 20 hr. rating	39 amp.hr.
Voltage and polarity	12 volt negative earth

Fuses

Quantity and rating	2, 35 amp.
---------------------	------------

Alternator

Type	Sev - Motorola A. 1230
Nominal system voltage	12
Charging voltage	13.2
Maximum output (hot)	30 amps. @ 3,000 r.p.m.
Control box type	Sev - Motorola E.144
Field coil resistance	5.2 +- .2 ohms. @ 25 C. measured across slip rings

Starter

Type	Paris - Rhone D.8 E 49
Drive	Pre - engaged
Lock torque	8 lbs.ft. (1.1 kg.m.) @ 355 amps.

Lamp Bulbs (all 12 volt)

Headlamp	- RHD, LHD	410 (45/40W) with 989 (6W) pilot
	- France	411 (45/40W) with 989 (6W) pilot
	- North America	Sealed beam unit
Front and rear indicators		382 (21W)
Indicator repeater		501 (5W capless)
Stop and tall lamps		380 (21/6W)
Rear number plate lamp		254 (6W festoon)
Reverse lamp	- Up to 46/0541	382 (21W)
	- From 46/0542	273 (21W festoon)
Interior lamp		254 (6W festoon)
Panel (instrument) lamps		987 (2.4W)
Warning lamps		987 (2.4W)

ADDITIONAL INFORMATION

Distributor Centrifugal Advance (Exhaust Emission):

Distributor <u>r.p.m.</u>	Distributor <u>degrees B.T.D.C.</u>
Below 550	No advance
800	2.5
1,000	10.5
1,250	11.5
1,500	13.0
1,750	14.5
2,000	15.5
2,250	16.5
2,400	17.0 Maximum advance

Distributor Vacuum Advance (Exhaust Emission):

Distributor degrees B .T.D.C.	Vacuum Hg. millimetres
1.3	100
3.3	150
4.5	200
5.6	250
6.5	300
7.0	350 Maximum advance

TORQUE LOADING FIGURES

ENGINE	lbs .ft.	kg.m.
Cylinder head - tighten cold (See also Section ' E')	54 - 60	7.46 - 8.29
Rocker arm pillar	15 - 20	2.07 - 2.76
Crankshaft - Main bearing caps	45	6.22
- Cone	30	4.14
- Sprocket	45	6.22
Flywheel	40	5.53
Oil pump - To cylinder block	9 - 12	1.25 - 1.65
- Strainer flange	16 - 20	2.25 - 2.75
Manifold to cylinder head	10 - 20	1.38 - 2.76

CLUTCH

Clutch assembly to flywheel	25	3.45
-----------------------------	----	------

TRANSMISSION

Gearbox casing (halves)	- 7 mm. bolts	15	2.07
	- 8 mm. bolts	20	2.75
Differential case to crown wheel	- 10 mm. bolts	45	6.22
	- 11mm. bolts	65-80	8.98-11.06
Differential bearing adjusting nuts		15	2.07
Pinion bearing nut		85	11.75
Speedometer drive worm		75 - 85	10.36 - 11.75
Reverse selector pivot		20	2.75
Side cover plates		15	2.07

FRONT SUSPENSION AND STEERING

Stub axle retaining nut		65 - 75	8.98 - 10.36
Ball joint	- To vertical link	38 - 42	5.25 - 5.80
	- To upper wishbone	12 - 15	1.65 - 2.07
Lower wishbone	- To trunnion*	35	4.83
	- To damper*	50 - 60	6.91 - 8.29
Inner wishbone retaining nut*		50 - 60	6.91 - 8.29
Caliper mounting plate to hub		22 - 27	3.04 - 3.73
Steering arm to vertical link		22 - 27	3.04 - 3.73
Steering tie-rod ball joint		26 - 28	3.59 - 3.87
Steering tie-rod adaptor		50	6.91
Steering column impact clamp		26 - 32	3.59 - 4.42

* Tighten with suspension in static condition

REAR SUSPENSION

	lbs.ft.	kg.m.
Lower link pivot bracket	18 -23	2.48 - 3.18

HUBS

Brake disc to hub	22 - 27	3.04 - 3.73
Front hub spindle nut *	5 - 6	.69 - .83
Rear hub retaining nut **	150	20.7

*Tighten nuts to this torque loading while rotating hub to ensure bedding of taper rollers. Slacken nut one 'flat', then insert split pin.

** Assemble with Loctite 'AV'. A rotational free play NOT EXCEEDING .005 in. (.127 mm.) between hub and shaft measured at the wheel stud should be used for LEFT - HAND hubs.

BRAKE HYDRAULIC SYSTEM CONNECTIONS

3/8 in. UNF female (bundy and hose connections)	8 - 10	1.10 - 1.38
3/8 in. UNF male (bundy to master cylinder, multi-ways, etc.)	5 - 7	.69 -.96
7/16 in. UNF male	7 - 10.5	.96 - 1.45
3/8 in. bore servo bundy (5/8 in.UNF male)	14 - 21	1.93 - 2.90
Stop lamp switch	12 - 15	1.65 - 2.07
Brake hose to banjo	12 - 15	1.65 - 2.07
7/16in. UNF female (bundy to reservoir)	12 - 14	1.65 - 1.93

Torque Wrenches

Torque wrenches in daily use should be checked at intervals, not exceeding 3 months, to ensure that accuracy is maintained.

GENERAL - NUTS AND BOLTS

1/4 in. UNF and UNC	5 - 7	.69 - .96
5/16 in. UNF and UNC	12 - 15	1.65 - 2.07
3/8 in. UNC	17 - 22	2.35 - 3.04
3/8 in. UNF	22 - 27	3.04 - 3.73
7/16 in. UNC	30 - 35	4.14 - 4.85
7/16 in. UNF	40 - 45	5.53 - 6.22
1/2 in. UNC	45 - 50	6.22 - 6.91
1/2 in. UNF	50 - 60	6.91 - 8.29
9/16 in. UNC	60 - 70	8.29 - 9.68
9/16 in, UNF	65 - 75	8.98 - 10.36
5/8 in. UNC	75 - 85	10.36 -11.75
5/8 in. UNF	100 - 110	13.82 - 15.20

Editors Notes:

[1] Page 11: Corrected .0228 to .0028. [JJ]

[2] Not in original manual. Added for clarification [JJ]

[3] Changed from "1.5 in. (3.8 cm.)" to correct original manual error. [JJ]