

SECTION O

LUBRICATION AND MAINTENANCE

<u>Section</u>	<u>Description</u>	<u>Page No.</u>
O.1	MAINTENANCE – GENERAL	3
O.2	FREE AFTER SALES SERVICE (300 MILES)	3
O.3	FREE AFTER SALES SERVICE (1,200 MILES)	4
O.4	'A ' SERVICE	5
O.5	'B ' SERVICE	6
O.6	'C' SERVICE	7
O.7	LUBRICATION GENERAL	9
O.8	ENGINE LUBRICATION	9
O.9	TRANSMISSION LUBRICATION	10
O.10	LOWER STEERING SWIVELS	10
O.11	BRAKE FLUID RESERVOIRS	11
O.12	RECOMMENDED LUBRICANTS	12

ILLUSTRATIONS

<u>Fig. No.</u>	<u>Description</u>	<u>Page No.</u>
1	Servo Unit	7
2	Engine and Transmission - Lubrication Points.	8
3	Engine Lubrication Points	8
4	Removing the Filter	9
5	Lower Steering Swivel Plug	10
6	Standard Master Cylinder – Reservoir	11
7	Tandem Master Cylinder – Reservoir	11

O.1 - MAINTENANCE - GENERAL.

In order to maintain this vehicle in an efficient, safe and economical running condition, regular and thorough servicing is essential. The Lotus voucher scheme has been established to provide this service and covers both lubrication and regular mechanical maintenance using recommendations laid down by the technical staff of Lotus Cars Limited.

The voucher service commences with a FREE "After Sales Service" which is carried out at 300 miles (500 km.), followed by a further FREE "After Sales Service" at 1,200 miles (2,000 km.). Further vouchers are included in the book to cover lubrication and maintenance at intervals of every 3,000 miles (5,000km.) up to and including 60,000 miles (100,000 km.).

Regular lubrication is essential for long life and sustained performance.

Make full use of these vouchers, which will be accepted by any Lotus Dealer throughout the United Kingdom or Overseas Territories. It is very important that the vouchers should be used in the correct sequence and at the appropriate mileage. If any particular service is accidentally omitted, the remaining sequence of operations will be affected.

Owners should appreciate that Warranty shall not apply to defect arising in any product which has not received the periodical maintenance as detailed in the Service Voucher Book.

It must be understood that all oils and materials used in these services will be charged for in addition to the charges for the services.

A lubrication chart and list of recommended lubricants are included within this section.

In line with our policy of continuous product improvement, Lotus Dealers are informed of all technical developments or improvements that have been made to subsequent vehicles, which could improve the performance of all vehicles.

Lotus Cars (Service) Limited reserve the right to change prices, specifications and equipment at any time without notice.

IMPORTANT - Brake seals, Hoses and Fluid.

The brake manufacturers recommend that at intervals NOT EXCEEDING 40,000 miles (65,000 km.) or 3 years, whichever is reached first, that the braking system be completely overhauled and all washers, seals and hoses renewed. Hydraulic servo units (if fitted) should be stripped, all old seals discarded, component parts cleaned and examined, and if in good condition, the unit rebuilt with the appropriate service repair kit.

It is also recommended that the brake fluid is renewed every 18 months.

Additionally, if a continental journey (or similar long distance strip) is being undertaken, it is recommended that the fluid is renewed, if this has not already been done in the previous 9 months.

O.2 - FREE AFTER SALES SERVICE. 300 miles (500 kilometres).

1. Lubrication.

Drain engine without flushing and refill with new oil.

Check sump for leaks. Fit new oil filter (DO NOT use the original filter, coloured orange, beyond this mileage). Check gearbox/differential oil level.

2. Engine.

Retighten cylinder head bolts to a torque loading of 58 lbs. ft.(8 kg.m.) after loosening a quarter-turn.

Readjust valve clearances.

Check engine mountings for security.

Check carburettor mountings for security.

Examine water hose connections and radiator expansion chamber level.

Check, and adjust if necessary, the alternator and water pump drive belts.

3. Ignition.

Check, and adjust if necessary, the distributor contact breaker points, and the static ignition timing.

Check sparking plug gaps.

4. Brakes.

Check braking system including handbrake for operation and correct adjustment.

Check pipework, hoses, front wheel discs and calipers, rear wheel backplates for security. Check brake fluid reservoir level (correct level is marked on reservoir); if low, check for leaks and rectify where necessary.

5. Clutch.

Check operation of clutch and adjust clearance if necessary.

6. Electrical.

Check electrical system throughout and operation of all circuits, including voltage regulator output.

Check electrolyte level of battery and top-up if necessary.

Check for tightness of terminals.

7. Wheels and tyres.

Check all road wheel nuts for tightness. Check all tyre pressures, including spare.

8. Body.

Check body operation generally and body securing points.

Check operation of all locks, catches, hinges, on doors and luggage compartment covers.

Check operation of screen washers.

Check seat sliding mechanism.

9. General.

Check fuel pipes, unions, fuel tank drain plug for security.

O.3 - FREE AFTER SALES SERVICE - 1,200 miles (2,000 kilometres).

1. Lubrication.

Drain engine without flushing and refill with new oil.

Drain gearbox/differential and refill with new oil.

2. Engine.

Retighten cylinder head bolts to a torque loading of 58 lbs. ft. (8kg.m.) after loosening a quarter turn.

Check tightness of rocker arm securing bolts.

Adjust valve clearances.

Check tightness of inlet and exhaust manifold securing nuts.

Check level of coolant in engine cooling system.

Check, and adjust if necessary the alternator and water pump drive belts.

3. Brakes.

Check brake fluid reservoir level. If low, check for leaks and rectify where necessary.

4. Electrical.

Check electrical system throughout and operation of all circuits, including voltage regulator output.

Check security of battery terminals.

Check electrolyte level of battery.

Check the condition of the ignition distributor contact points, adjust if necessary. Check sparking plug gaps.

5. Steering and Suspension.

Check that all steering connections, including rack and pinion mountings, steering column adjusting clamps are secure. Check front wheel alignment. Check wishbone and damper connections on front and rear suspension units.

6. Wheels and tyres.

Check all tyre pressures including spare.

7. Body.

Check operation and lubricate all door locks, hinges, catches on doors and luggage compartment covers.

Check operation of windscreen wiper and washers.

8. General.

Check tightness of drive shaft universal joints securing bolts. Carry out brief road test and make necessary adjustments. Wash car. Ensure steering wheel and upholstery are free from grease.

Exhaust Emission Control System Vehicles.

Check the initial timing of the ignition distributor; adjust if necessary. Check the tightness of the intake and exhaust manifold nuts and of the carburettor securing nuts. Tighten if necessary, but not excessively.

Check the operation of the solenoid valve.

Check the idle R.P.M. adjust if necessary.

O.4 - "A" SERVICE - every 3,000 miles (5,000 kilometres) or 3 months (whichever is sooner).

1. Lubrication.

Drain engine without flushing and refill with new oil.

Fit new oil filter. (Fit new oil filter at first 3,000 miles- 5,000 Km. and 6,000 miles - 10,000 Km. then subsequently every 6,000miles - 10,000 Km). Check gearbox/differential oil level and top-up if required.

Lubricate drive shaft universal joints with grease.

Lubricate all door and luggage-compartment locks, catches and hinges.

2. Engine.

Check coolant level in radiator expansion chamber. Check air cleaner element for condition, Remove as much as possible of any accumulated dust.

3. Brakes.

Check brake fluid reservoir level and top-up if necessary.

Check brakes, system and operation, including handbrake; adjust if necessary. If front wheel disc pads are down to 3/32 in. (2.5 mm.), replace pads. Check security and condition of all brake hydraulic and, vacuum pipes and unions (where fitted).

4 Ignition.

Check distributor settings and adjust if necessary.

Check the condition of the ignition distributor contact points, adjust if required.

Check sparking plug gaps and adjust if necessary.

5. Electrical.

Check operation of all electrical circuits. Check electrolyte level of battery. Clean battery posts and terminals and smear with silicone grease. Ensure tightness of earth (negative) terminal.

6. Steering and Suspension.

Check steering assembly for general condition.

Check front wheel alignment and adjust if necessary.

7. Wheels and Tyres.

Dynamically balance wheel and tyre assemblies.

Check all tyre pressures, including spare.

B. Body.

Check correct operation of all door locks, hinges and catches on luggage compartment covers. Check body condition generally, and all attachment points, including bumper mounting bolts.

Check heater system and operation of valve.

Check level of water in windscreen washer container.

Exhaust Emission Control System Vehicles.

Check the initial timing of the ignition distributor; adjust if required. Check the tightness of the intake and exhaust manifold nuts and of the carburettor securing nuts. Tighten if necessary, but not excessively.

Check the operation of the solenoid valve.

Check the idle R.P.M., adjust if necessary.

O.5 – "B" SERVICE - every 6,000 miles (10,000 kilometres) or 6 months (whichever is sooner).

"A" Service, plus the following:

1. Lubrication.

Drain gearbox/differential and refill with new oil.

2. Engine.

Fit new crankcase ventilation filter element. Renew air cleaner element. Check securing bolts for tightness on carburettor, inlet and exhaust manifolds, and exhaust system.

Check and adjust if necessary, alternator and water pump drive belts.

Check and adjust if necessary, valve rocker clearances.

3. Brakes.

Renew servo unit air filter element (if fitted).

4. Ignition.

Check each sparking plug for condition and gap. Adjust gap if required, or replace sparking plug with new one if condition or mileage make replacement necessary.

Lubricate distributor cam and counterweights sparingly.

5. Clutch.

Check operation of clutch and adjust if necessary.

6 Steering and Suspension.

Lubricate lower steering swivels.

Repack front hub bearings with grease.

7 Electrical.

Check headlamps focusing and reset if necessary.

Check voltage regulator output.. Check windscreen wiper operation, and arc.

8. General.

Check tightness of nuts and bolts securing front wheel discs, caliper mountings, drive shaft universal joints, steering rack and pinion mountings, front and rear suspension attachment points and damper mountings.

Exhaust Emissions Control System Vehicles.

Replace the air filter element with a new one.

Clean the PCV system flame arrestor.

9. Servo unit.

The vacuum servo unit, when fitted is situated in the left-hand side of the lower front luggage compartment (see Fig. 1).

Servicing

The air filter should be changed every "B" Service 6,000 miles (10,000 Km.).

O.6 – "C" SERVICE – Every 12,000 miles (20,000 kilometres) or 12 months (whichever is sooner).

"A" and "B" Service, plus the following:

1. Engine.

Drain, fluid out and refill the cooling system, including heater, with a suitable anti-freeze solution.

2. Ignition.

Fit new sparking plugs.

3. General.

Check for wear on all foot pedal operating cables, linkages and bearings.

Lubricate steering unit.

NOTE: Any faults or inconsistencies in the operation of any components should be brought to the Owner's attention.

Emissions Control System Vehicles.

Clean the exposed parts of the carburettor, **DO NOT** dismantle it.

Clean the "AC" valve, or replace it with a new one if necessary.

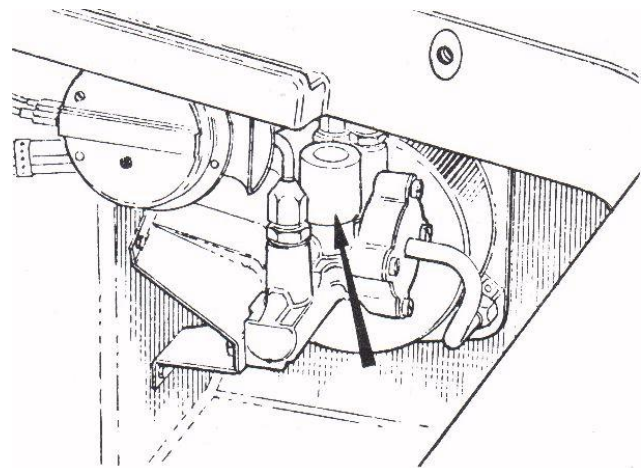

Fig. 1 - Servo Unit.

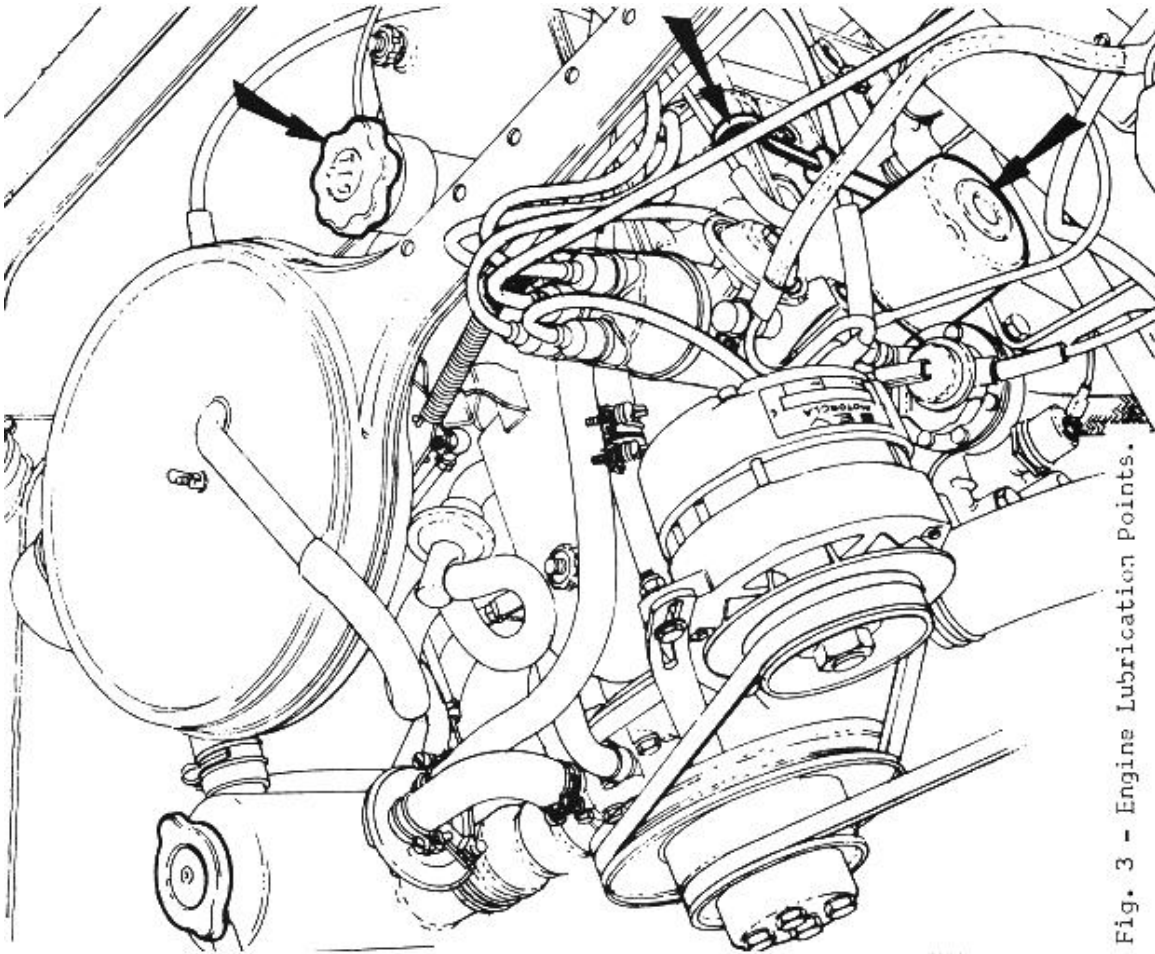

Fig. 3 - Engine Lubrication Points.

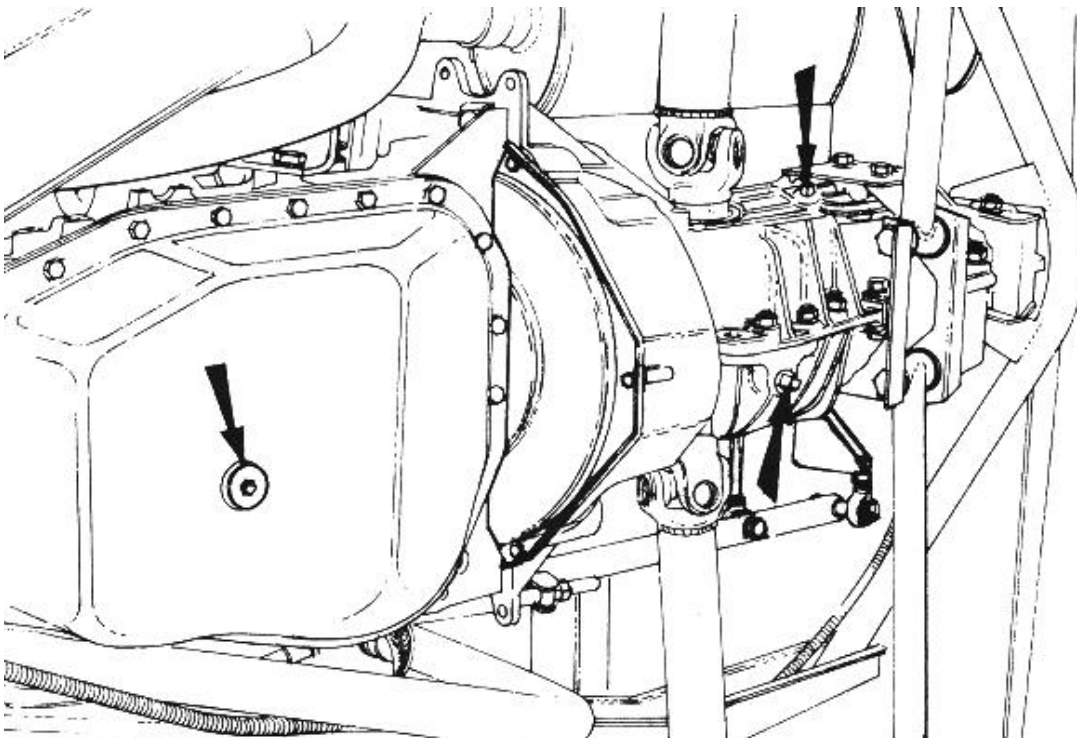

Fig. 2 - Engine and Transmission, Lubrication points.

O.7 - LUBRICATION - GENERAL.

Regular lubrication is essential for long life and sustained performance, and the correct intervals for lubrication, as given in the Service Voucher Book (Part No. 46T 326) should be strictly followed. It is most important that only the grade of lubricant shown in the table is used, otherwise serious damage may result.

Recommended lubricants: see table page 12.

O.8 - ENGINE LUBRICATION.

To ensure their longevity new engines should have two initial oil changes (both carried out during the "After Sales Service").

Engine should have their oil drained after first 300 miles (500 km.) and refill with fresh oil. They should also be drained at 1,200 miles (2,000 km.) and be refilled with new oil.

Subsequent oil changes should be made at 3,000 miles (5,000 Km.) intervals.

The correct level is to the top mark on the dipstick, which is located to the right-hand side of the cylinder block. The oil filler cap is at the forward end of the rocker cover.

Inspect the oil level daily, topping-up if necessary to the correct level. **DO NOT** overfill.

Replace the oil filler cap securely otherwise an oil loss will occur and could result in a complete failure of the engine lubrication system.

Draining the sump.

Draining the sump will be greatly facilitated if carried out when the car has just completed a run and the oil is warm, thus flowing more readily.

Allow to drain thoroughly. Clean the drain plug and replace.

Ensure that your garage attendant replaces the cap correctly.

The drain plug is located at the right-hand rear of the sump.

NOTE: If the engine oil is renewed at the recommended intervals there is no necessity to use a flushing oil. The use of a flushing oil is **NOT** recommended because of the difficulty in draining it completely.

Oil filter.

It is recommended that the oil filter element be renewed at intervals of every 10,000 Km. (6,000 miles).

It is pointed out that it is false economy to fit a new oil filter alone; always refill engine with new oil after draining the sump.

Loosen the filter by means of tool (Part no 46E 6432).

- Pass the strap round the filter and insert it into the stirrup.
- Tension the strap.
- Loosen the filter.
- Remove the tool and unscrew the filter by hand.
- Oil the new filter seal with engine oil.
- Screw in the filter until the seal makes contact with the locating area on the cylinder block.

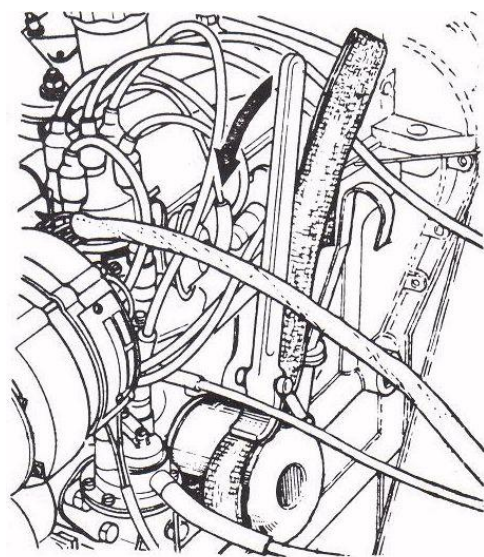

Fig. 4 - Removing the Filter.

Tighten the filter by hand by $\frac{1}{4}$ of a turn: the reference 1 - 2 - 3 and 4 on the can help one to carry out this operation correctly.

Unscrew the filter, bring it in contact with its locating base and re-tighten it by $\frac{1}{2}$ to $\frac{3}{4}$ of a turn.

NOTE - Use only oil filters with crimped seals. Refill engine with fresh oil.
Run engine and check for leaks.

O.9 - TRANSMISSION LUBRICATION.

The transmission oil level should be checked every 3,000 miles (6,000 km.) and replenished if necessary.

A combined filler/level plug is located on the left-hand side of the casing, while the drain plug is at the bottom of the casing.

To maintain the correct quantity of lubricant, ensure that the oil reaches the bottom of the filler/level plug orifice when the vehicle is standing in a level condition.

It is suggested that this check is not performed immediately after the vehicle has been used as the 'churning' effect may result in a false reading.

Lubricant should be drained at intervals of every 6,000 miles (10,000 km.) preferably when the oil is warm when the car has just completed a run, thus allowing it to flow more readily.

Allow to drain thoroughly, clean the drain plug and replace.

It is important that only Hypoid oils of the approved grade be used in the transmission if damage to the gears is to be avoided.

O.10 - LOWER STEERING SWIVELS.

At intervals of every 6,000 miles (10,000 km.), remove the plug "A" (Fig. 5) [1] and fit a screwed nipple. Apply a grease gun filled with 90 EP Hypoid oil to the nipple and pump the gun until oil exudes from the swivel.

Remove the nipple, refit the plug, and repeat with the opposite swivel.

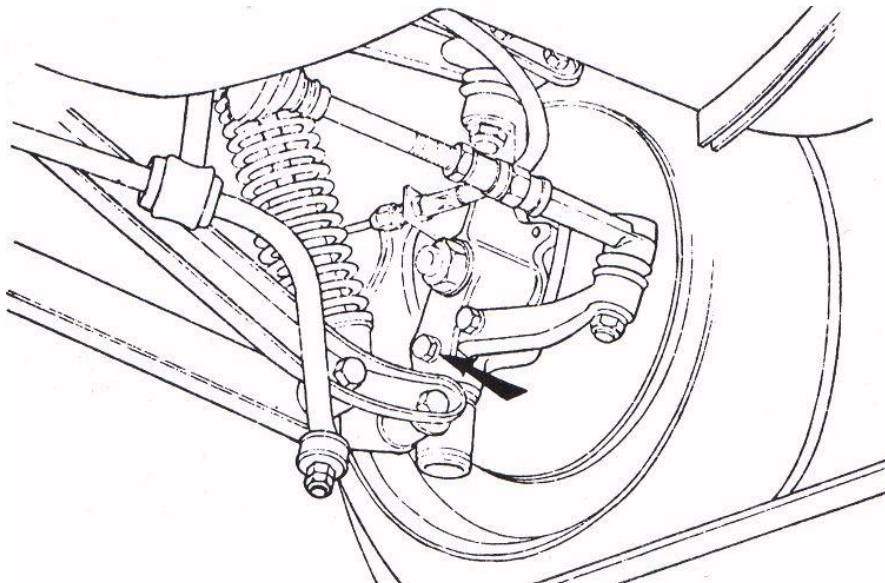

Fig. 5 - Lower Steering Swivel Plug.

O.11 - BRAKE FLUID RESERVOIRS.

The brake fluid reservoir is located in the front luggage compartment, on the driving side (see Fig. 6) [2]. Check fluid level in the reservoir at intervals of every 3,000 miles (5,000 Km) topping-up if necessary to within 12 mm (½ in.) of the top.

Use only the specified fluid for topping-up.

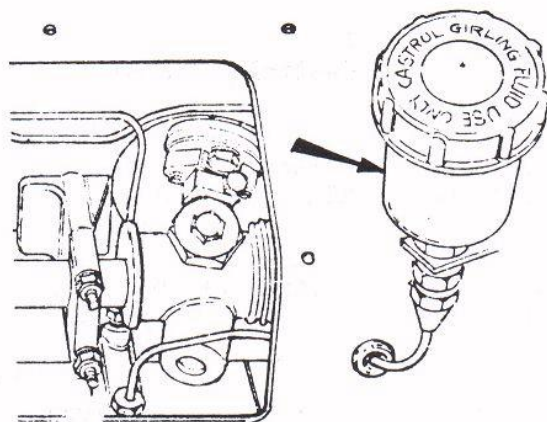

Fig. 6 - Standard Master Cylinder Reservoir.

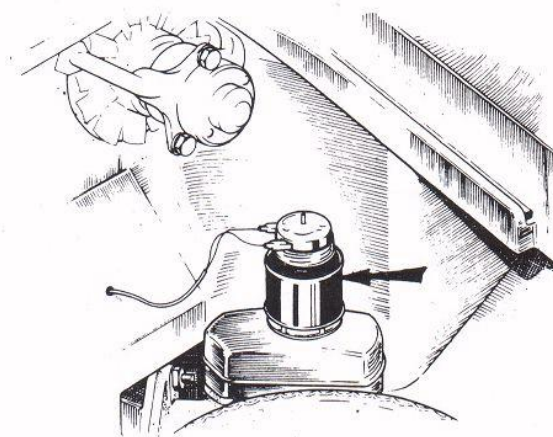

Fig. 7 - Tandem Master Cylinder Reservoir.

O.12 - RECOMMENDED LUBRICANTS.

(The products shown are not listed in order of preference).

	Shell	Esso	B.P.	Castrol	Mobil
<u>Engine (above 0°C)</u>	Shell Super 100	Esso Uniflo 20W/50	Super Viscostatic	Castrol GIX	Mobil Mobiloil Super
<u>Engine (below 0°C)</u>	Shel Super 10l	Esso Uniflo	Super Viscostatic	Castrolite	Mobiloil Special 10W/30
<u>Transmission</u>	Shell Spirax 80 EP	Esso Gear Oil GX 80	B.P. Gear Oil 80 EP	Castrol Hypoy Light	Mobilube GX 80
<u>Front Hubs</u>	Shell Retinax 'A'	Esso Multi- purpose Grease	B.P. Energrease L.2	Castrol Grease LM	Mobil- Grease MP
<u>Steering swivels</u>	Shell Spirax 90 EP	Esso Gear Oil GP 90/140	B.P. Gear Oil SAE 90 EP	Castrol Hypoy	Mobilube GX 90
<u>Steering Unit</u>	Shell Retinax 'A'	Esso Multi- Purpose Grease	B.P. Energrease L.2.	Castrol Grease LM	Mobil Grease MP

Pivots and Linkages Engine oil.

Hinges, locks, catches Engine oil or silicone grease

Brake master cylinder reservoir: Castrol Girling Brake and Clutch Fluid Crimson to specification SAE 70 R.3.

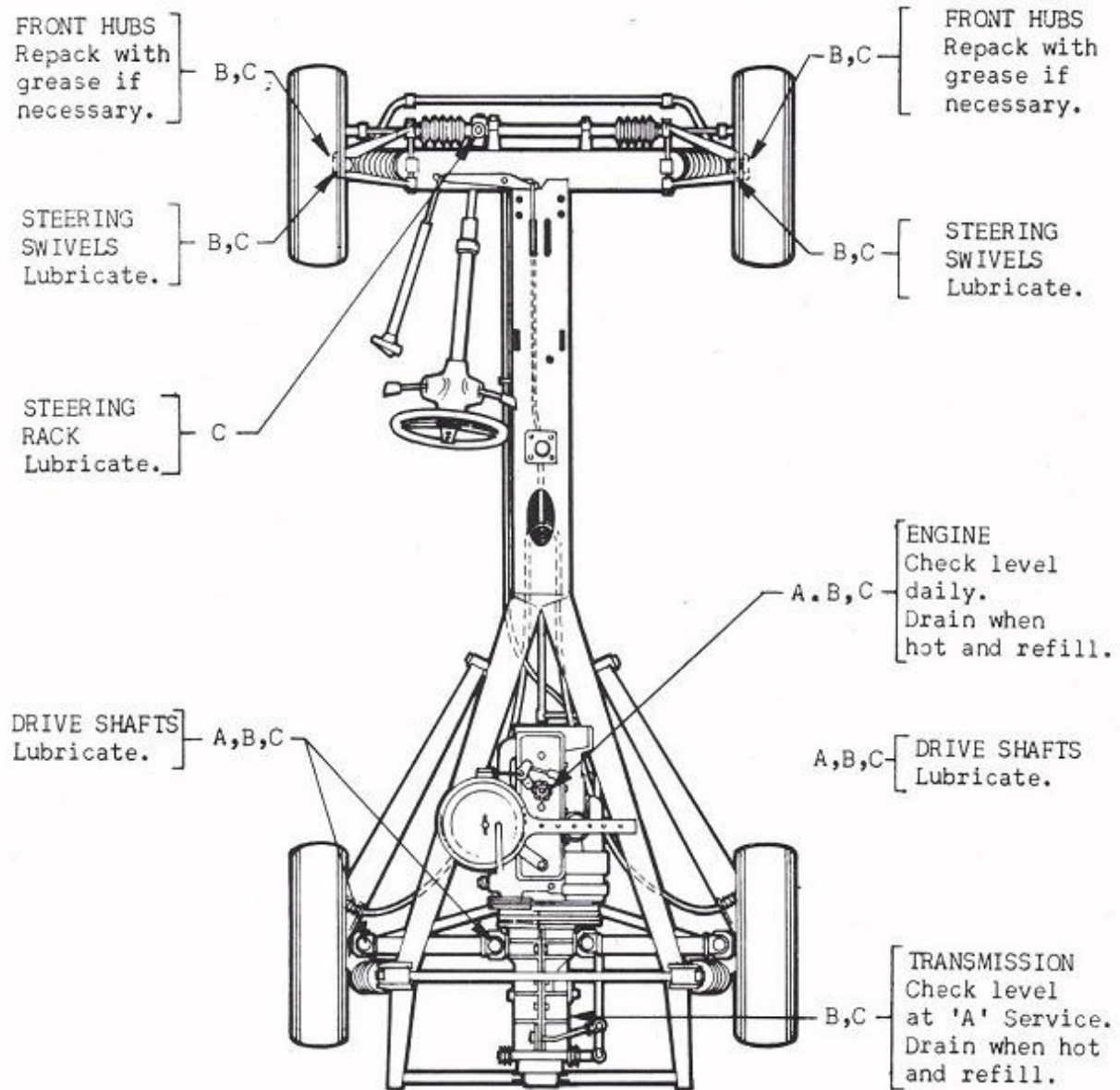

Fig. 8 - Lubrication Diagram. [3]

Editors notes:

[1] Original text referenced Fig. 4. Corrected to Fig. 5 [JJ]

[2] Original text referenced Fig. 5. Corrected to Fig. 6 [JJ]

[3] Image was labeled Fig 6. Renamed Fig. 8 to eliminate duplication. [JJ]