

Lotus Europa S1 Parts Manual - Section M3 - Electrical - Distributor - Page 2

Item	Lotus #	S1	S1A/B	S2	S2 Fed	TC	TC Fed	TCS	TCS F	LHD	RHD	Description	Change Point Notes Bulletin Reference
46M6055	46M6055	1	1									Distributor (697-04)	
1081300452	1081300452	1	1									Star Washer	
46M6089	46M6089	1	1									Advance Spring	
46M6090	46M6090	1	1									Advance Spring	
46M6075	46M6075	1	1									Shaft	
46M6074	46M6074	2	2									Washer	
46M6078	46M6078	1	1									Washer	
46M6065	46M6065	1	1									Contact Breaker Connection	
46M6061	46M6061	1	1									Spacer	
46M6077	46M6077	1	1									Washer	
46M6076	46M6076	1	1									Washer	
46M6070	46M6070	1	1									Tension Pin	
46M6071	46M6071	1	1									Spring	
46M6069	46M6069	1	1									Drive Pinion	
46M6085	46M6085	1	1									Cap	
46M6084	46M6084	1	1									Screw - Washer and Washer	
46M6091	46M6091	1	1									Contact Breaker Cam	
46M6068	46M6068	4	4									Circlip	
46M6058	46M6058	1	1									Washer	
46M6067	46M6067	1	1									Spacer	
46M6083	46M6083	2	2									Spacer	
46M6082	46M6082	2	2									Machanical Advance Weight	
46M6073	46M6073	2	2									Clip - Cap Attaching	
46M6088	46M6088	1	1									Vacuum Advance Unit	
46M6059	46M6059	1	1									Condensor - Distributor	
1081200446	1081200446	1	1									Washer	
8070040120	8070040120	1	1									Screw	
1081300452	1081300452	1	1									Star Washer	
46M6056	46M6056	1	1									Distributor Cap	
46M6064	46M6064	1	1									Brush - Distributor Cap	
46M6062	46M6062	1	1									Rotor Arm - Distributor	
46M6060	46M6060	1	1									Clip - Contact Breaker Retaining	
46M6066	46M6066	1	1									Washer	

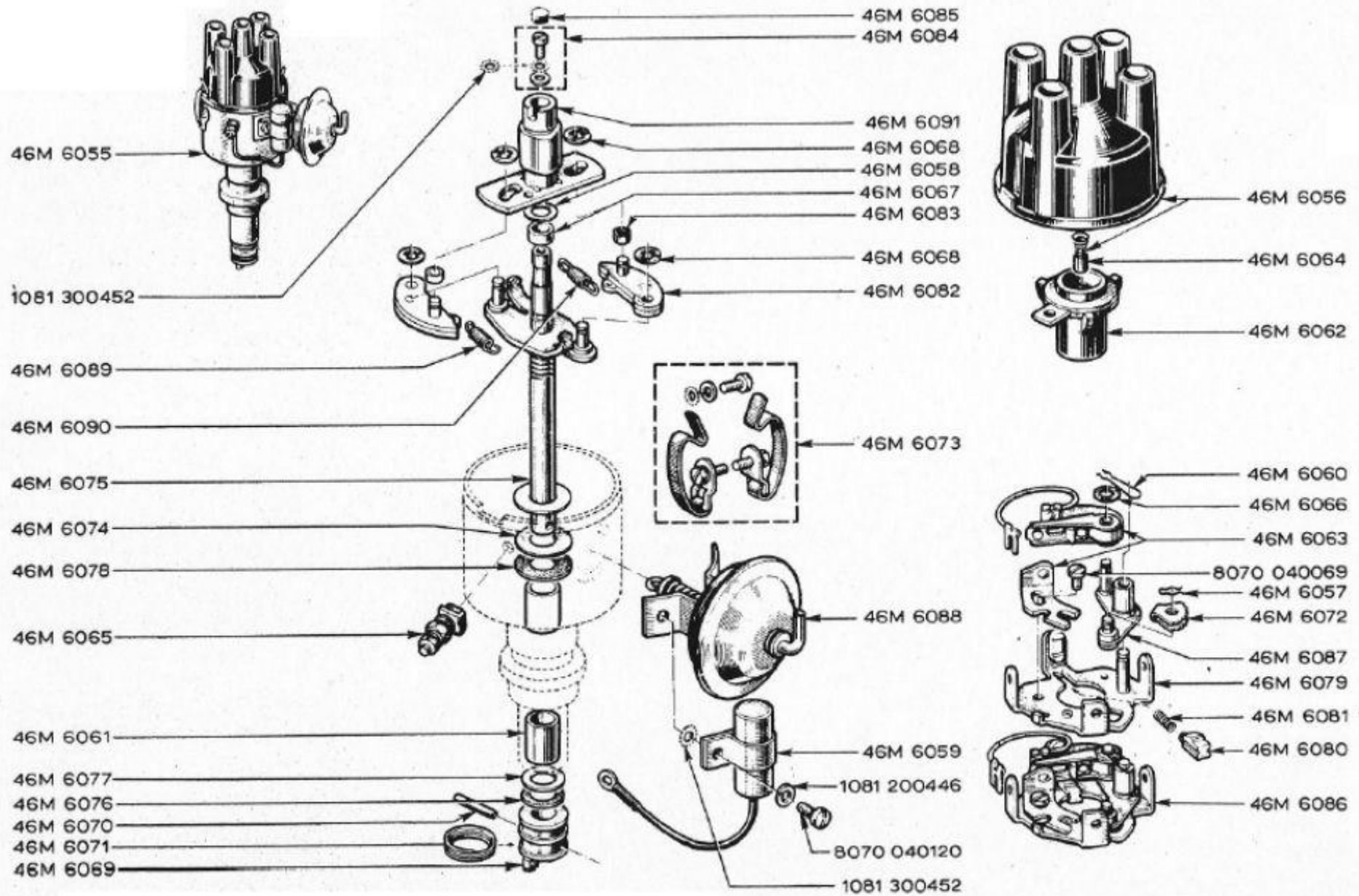

Lotus Europa S1 Parts Manual - Section M3 - Electrical - Distributor - Page 4

Item	Lotus #	S1	S1A/B	S2	S2 Fed	TC	TC Fed	TCS	TCS F	LHD	RHD	Description	Change Point Notes Bulletin Reference
8070040069	8070040069	1	1									Screw	
46M6057	46M6057	1	1									Clip - Vacuum Advance Cam	
46M6072	46M6072	1	1									Vacuum Advance Cam	
46M6087	46M6087	1	1									Contact Breaker Cam	
46M6079	46M6079	1	1									Contact Breaker Mounting	
46M6081	46M6081	1	1									Spring	
46M6080	46M6080	1	1									Vacuum Advance Follower	
46M6086	46M6086	1	1									Contact Breaker Assembly	
46M6063	46M6063	1	1									Contact Breaker Set (points)	