



Lotus Service Bulletin

CLASS: 111
NUMBER: 1971/24
TYPE: Europa
Date: 23.4.1971

LOTUS CARS Ltd - NORWICH NORFOLK NOR92W - Tel: WYMONDHAM 3411 - CABLES LOTUS NORWICH TELEX 97401

Circulation List	Service Manager		Foreman			
------------------	-----------------	--	---------	--	--	--

Title: Improved Gearshift Linkage and Reverse Lamp Switch as fitted in current Production.

Reason: To introduce an improved linkage which gives more positive and lightened operation and to introduce an improved reverse lamp switch.

This linkage can be fitted to any Series II car built to an earlier specification, with slight alterations to the car.

Parts Required: See separate parts bulletin.

Charges: U.K. - WarrantyNO
 Export - Factory.....NO
 - Distributor.....NO

Action: a. Gearshift Linkage

To fit the improved linkage to existing cars, proceed as follows.
The Section references made are all contained in the Lotus Europa Workshop Manual (Part No, 46 T 327).

1. Raise the rear of the car and support with suitable stands. Support the engine/transmission unit with a separate stand.
2. Disconnect the clutch cable (Section 'Q').
3. Remove the entire existing gearshift linkage, including the gear lever and the R/H engine mounting bracket.
4. Remove rear Selector housing from back of gearbox (Section 'F').
Remove the breather from the top of the housing. Pull off rubber boots from each end of cross-shaft and release circlip securing the return spring. Pull off spring abutment, spring and cup (Fig. 1.).
5. Insert a suitable sized drift through the breather hole on top of the rear housing and knock out tension pins (inner and outer) securing selector fork to shaft. Slide cross-shaft out towards the return spring side. Remove reverse spring and shorten to give a free length of 4.25 in (107.95 mm.).
6. Drill a second hole of .25 in. (6.35 mm.) diameter on each 'leg' of the relay lever mounting bracket on the chassis. This second hole should have its centre .30 in (7.62 mm.) from the centre of the existing hole (see Fig. 2.).

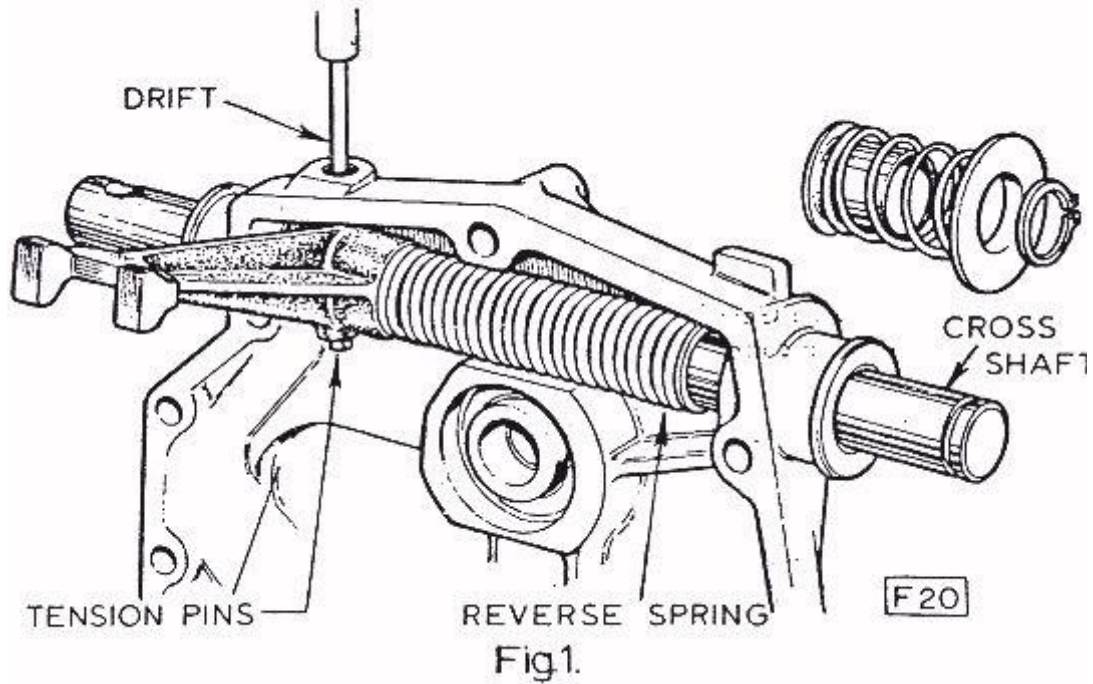

Extreme care must be exercised during this operation as the hole is quite close to the edge of the bracket

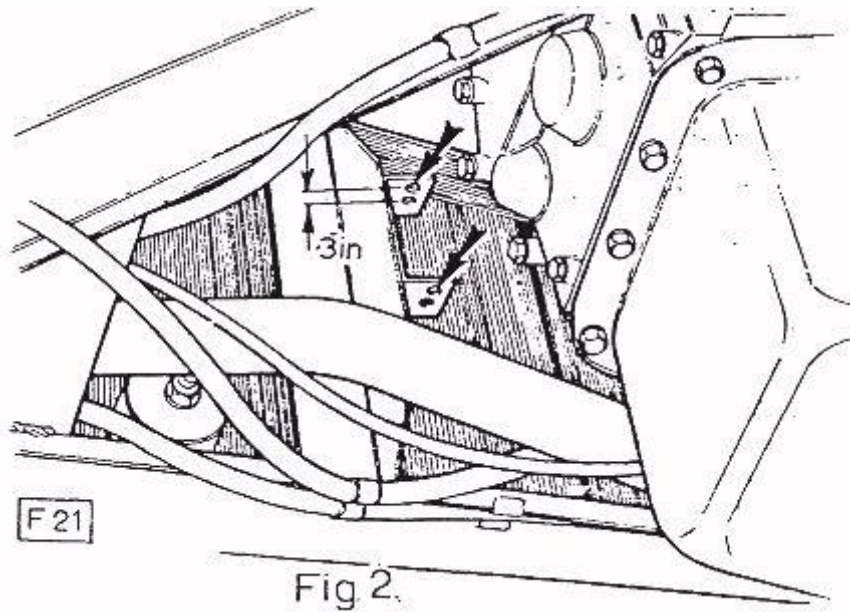

7. Enlarge the lower half of the hole in the chassis diaphragm by .25 in (6.35 ram) (Fig. 3). Fit new engine mounting bracket and insert new rear longitudinal link (See Fig. 4).

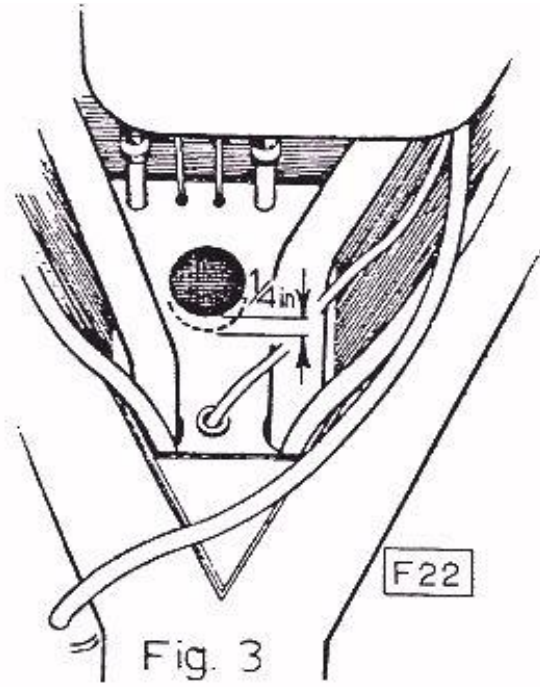

Fig. 3

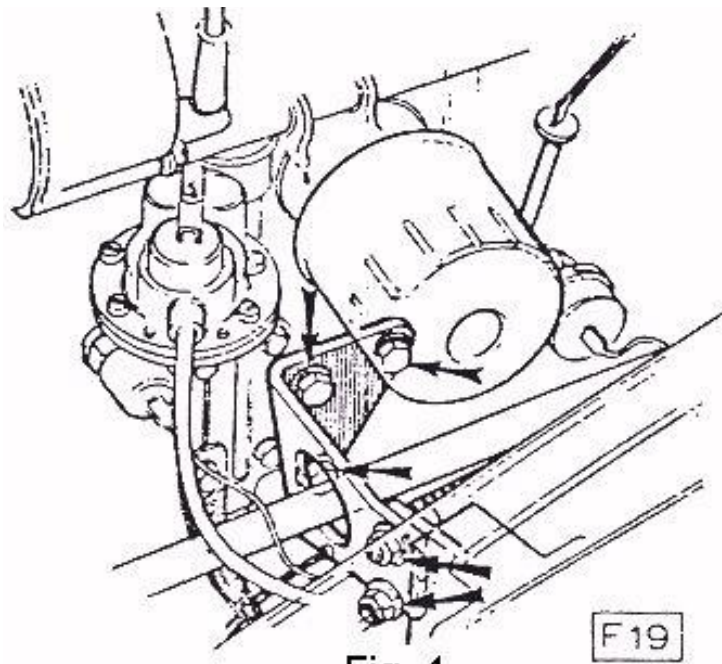
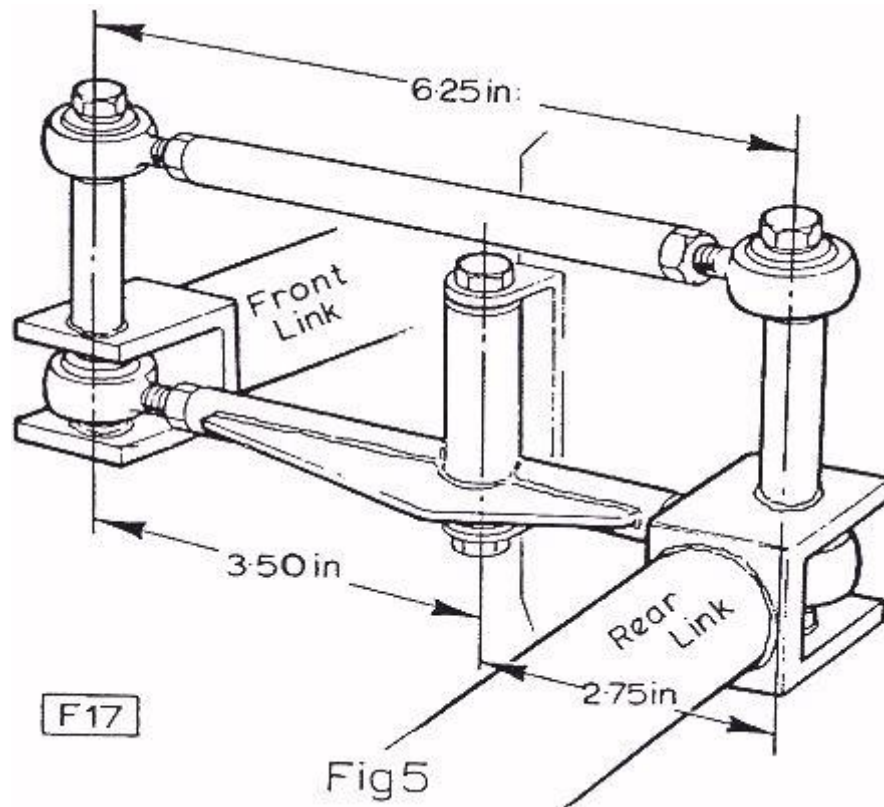

Fig. 4

8. Assemble actuator to gearbox cross-shaft (on rear housing), using the 7 mm. roll pin for its retention.

9. Insert front longitudinal link into chassis backbone and attach gearlever. Attach bearing plate, spacer and circlip to chassis backbone and gearlever.

10. Attach relay lever and link tube to the rear longitudinal link. Attach relay lever to chassis bracket, using the newly drilled holes in the bracket. Attach front longitudinal link to the free ends of the relay lever and link tube. Adjust ball joints on front and rear longitudinal links and on the link tube to give the dimensions shown in Fig. 5. Liberal greasing of the inner surfaces of pivot tubes (on ends of front and rear links) is desirable, BEFORE inserting the pivot bolts.



11. Attach the rear longitudinal link to the actuator and adjust ball joint to give the dimension shown in Fig. 6. Attach location link between rear longitudinal link bracket and gearbox.

Notes: All 5/16/in. locknuts should be torque loaded to 15 lbs. Ft. (2.074 kg. M.) and 3/8 in. locknuts to 25 lbs. Ft. (3.456 kg. M.).

Estimated time for this conversion is 8 hours.

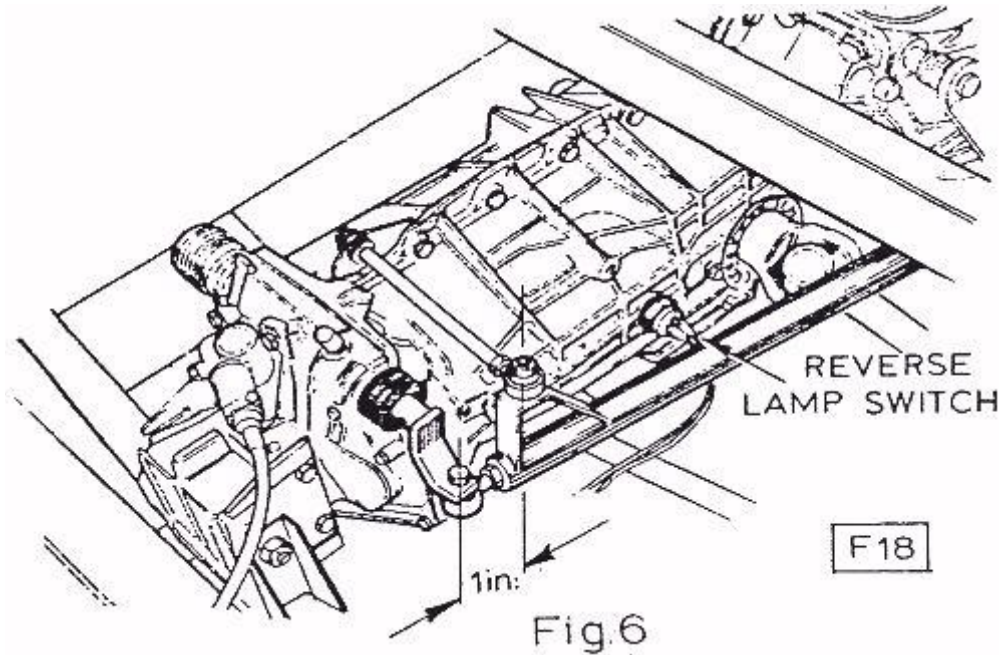

b. Reverse Lamp Switch

1. Disconnect the battery. Release the cable from the existing switch and remove switch.
2. Remove the plug (just behind the R/H drive shaft) in the side of the gearbox casing and discard.
3. Screw in the new reverse lamp switch. Attach extension cable to existing cable and to switch.
4. Re-connect the battery.