



LOTUS SERVICE BULLETIN

Class	III
Number	1970/5
Type	Non Emission
Date	Stromberg Carbs. 1.1.1970

LOTUS CARS (SERVICE) Ltd NORWICH NORFOLK NOR92W Tel: WYMONDHAM 3411 CABLES LOTUS NORWICH TELEX 97401

Circulation List	Service Manager		Foreman				
------------------	-----------------	--	---------	--	--	--	--

Title: Stromberg Carburetters - Non Emission

Reason: To introduce an air valve assembly with adjustable needle and to detail the adjusting procedure.

Parts Required: Air Valve Assembly with adjustable needle.
 (Supplied F.O.C. for fitting to Non-Emission engines not already so fitted). Part No. 36S 6171
 Tool, Needle Adjusting Part No. 36S 6172

Price: 36S 6171 £2.10.0. £2.50 (New Pence) each U.K. Recommended Retail.
 36S 6172 £1.10.0. £1.50 (New Pence) each U.K. Recommended Retail.

Fitting Time:

Charges: U.K. - Warranty.....YES
 EXPORT - Factory.....YES
 - Distributor.....NO

Action: In the event of complaints relating to poor running, misfiring etc. the following action should be taken:-

1. Check the ignition timing. The correct figures for Non-Emission engines are 9° static and 14° at 950 r.p.m. (stroboscopic).
2. Check spark plug gaps (.020 in., .508 mm.) and contact breaker points gap (.014/.016 in., .35mm./.40mm.)

Where the Stromberg Carburetters are fitted with a non-adjustable needle, the air valve assembly with adjustable needle may be fitted as described below:-

1. Remove the carburetter air box.

2. Remove each top cover and withdraw each air valve assembly.
3. Using a depth gauge, check the distance from the carburetter bridge to the face of the main jet. The correct dimension is .120 in. (.3048 mm.) \pm .003 in. (.00762 mm.).
If the dimension is less than .120 in. (.3048 mm.) reset the jet with the proper tool as previously supplied (See Class II Service Bulletin 1969/8)
If the dimension is too large, remove the float chamber and tap the main jet upwards using a locally made hollow cylindrical drift as shown in Fig.2.
Finally, reset the jet from above as described in the above mentioned Bulletin.
Replace the float chamber.
4. Discard the air valve assembly with fixed needle.
5. Insert the special needle adjusting tool into the damper tube of the new air valve. By turning the inner rod of the tool set the needle shoulder in line with the face of the air valve.
6. Fit the new air valve assembly into the carburetter, guiding the needle into the main jet with a finger in the air intake, and replace the top cover.
7. Start the engine and allow it to reach running temperature (minimum 70°C.).
8. Using a Cryton 'Synchrocheck' or similar, balance the air flows through the carbueretters. Slacken the clamp on the 'W' clips to carry out this adjustment.
(See also Section 'L.14' in the Elan + 2 Workshop Manual).
9. With the finger, block each leak vent (Fig.1) in turn and observe the drop in r.p.m. (This action enriches the mixture). Remove the damper assembly, insert the adjusting tool in the damper tube, and adjust the needle in each as required to achieve a similar action on each carburetter.
10. Adjust the needle to give a weak mixture, by turning anti-clockwise. This can be determined by 'blipping' the engine and observing a 'stagger' at idling speed. Increased weakening will make the engine cut after a 'blip'.
11. Adjust both needles to give a richer mixture (clockwise) until the engine will not cut after a 'blip' and there is only a slight 'stagger' at idling speed.
12. Check that there is sufficient 20/50 oil in the damper chambers and replace the damper assemblies.

13. Replace the airbox and finally set the slow running to 950 r.p.m.

When an air valve assembly with adjustable needle is fitted to a carburetter, the complete assembly must be removed before any attempt is made to reset the main jet. Resetting the jet with a drift passed down on the damper tube, as described in Service Bulletin 1969/8 (Class II), will result in damage to the needle adjusting mechanism.

When the adjustments described above have been correctly carried out, it should be found that the slow running and response are satisfactory. If this is not so, and it is certain that the adjustments have been correctly carried out, the operation of the distributor should be checked. If this is correct through the range the carburetters should be changed or the advice of the Field Service Controller sought.

Cases have occurred, particularly in town or traffic driving, of plugs fouling after a few days. Should this happen, the ignition system should be carefully checked. If a car is used exclusively for town driving, Autolite AG 32 plugs may be fitted, or otherwise Champion N7Y as currently fitted to some Rover cars. When neither of these plugs effects a cure, a higher out put coil should be fitted after reference to the Field Service Controller. Carburetters with the adjustable needle air valve assemblies have been fitted to Elan cars from Engine Number 19701 and Elan + 2 from Engine Number 19740. These air valve assemblies are available F.O.C. to cars not already so fitted on application to the Field Service Controller or your Service Representative. They are available only in limited quantities at present. The needle adjusting tool, Part Number 36S 6172, is available from Parts Department, Lotus Cars (Service) Limited,

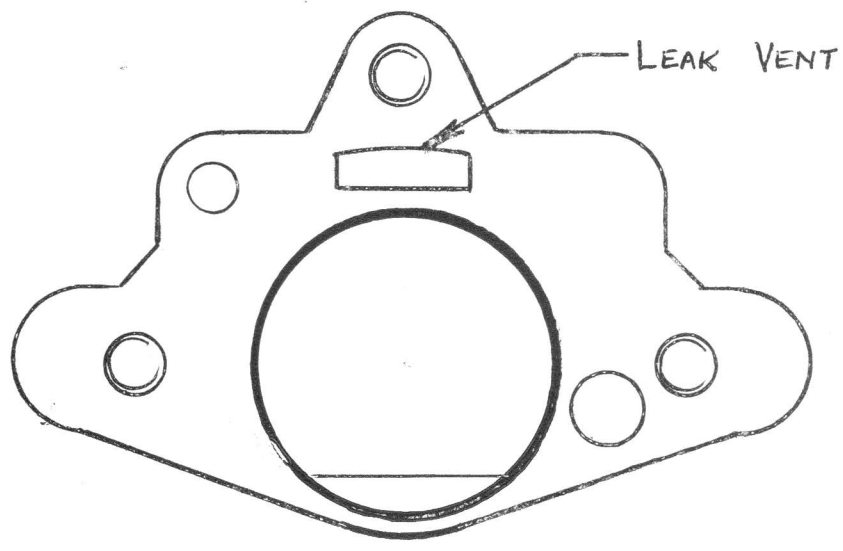

FIG. 1.

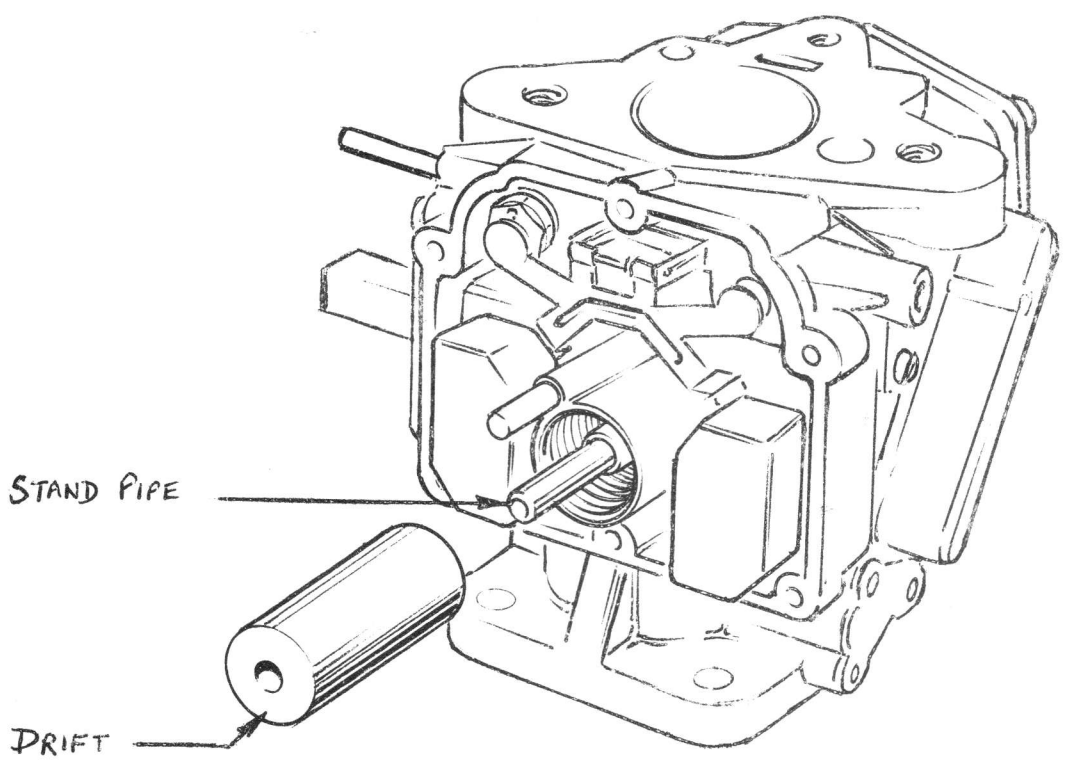

FIG. 2.