



LOTUS SERVICE BULLETIN

Class	III
Number	1969/28
Type	Europa
Date	1.12.1969.

LOTUS CARS (SERVICE) Ltd NORWICH NORFOLK NOR92W Tel: WYMONDHAM 3411 CABLES LOTUS NORWICH TELEX 97401

Circulation List	Service Manager		Foreman				
------------------	-----------------	--	---------	--	--	--	--

Title: Radio and Suppression Kit.

Reason: To give instructions in the fitting of a radio and a radio suppression kit.

Parts Required: Radio Receiver Unit - Model 1070 54 M 6039 1 off
or Model 1072 54 M 6043 1 off
Aerial 54 M 6047 1 off
Fixing and Suppression Kit 54 M 6048 1 off
Engine Screening Plate 54 M 0110 1 off
Engine Screening Plate 54 M 0111 1 off
Engine Mounting 54 E 6000 2 off

Price: 54 M 6043 To be advised
54 M 6039 £25.15. 2d. £25.76 (New Pence)
54 M 6047 £ 1.12. 8d. £ 1.63 (New Pence)
54 M 6048 £11.11. 0d. £11.55 (New Pence) each U.K.
54 M 0110 £ 1.12. 0d. £ 1.6 (New Pence) recommended retail
54 M 0111 £ 1.15. 0d. £ 1.75 (New Pence)
54 E 6000 16. 6d. £ 0.83 (New Pence)

Fitting Time: 8 hours.

Charges: U.K. - Warranty.....NO
EXPORT - Factory.....NO
- Distributor.....NO

Action: Disconnect the battery. Inspect the two standard earthing connections on the car which are the engine to chassis braid and fascia to chassis bracket, to ensure that they are in good order.

SUPPRESSION KIT

General Points: Ensure that all metal to metal connections are clean and secure to give good electrical contact. The various items of the suppression kit are supplied in five small packages in addition to the two engine screening plates (Part Numbers 54 M 0110 and 54 M 0111). The items in each package will be dealt with separately.

Screening Plates: Elongate the hinge mounting holes on the upper plate and scrape the paint from round the three holes in the flange of this plate. Remove the nut from the outer bolt on each hinge and the screws along the inner edge of the engine compartment grilles and fix the plate to the engine compartment lid by replacing these screws and nuts.

Move the seats as far forward as possible and remove the rear trim panel which is held by one push connector on either side. Hold the bulkhead screening plate in position, making certain that it is not touching the wiring loom or petrol pipe which pass across the engine compartment at the bottom of the bulkhead. Drill .25 in. (6.35 mm.) holes through the bulkhead in positions corresponding to those in the screening plate. Scrape the paint from around all holes and mount the screening plate using bolts passed through from the front.

Package No. 1: Remove the ignition coil from its mounting position on the RH side of the engine compartment. Scrape the paint away in the area of the mounting bracket. Replace it, fixing the clip of the 1 mfd. condenser and one end of the long plastic covered earth braid under one of the mounting bolts. Connect the condenser lead to the SW (BAT) terminal on the coil. Secure one end of each of the two remaining earth braids to each of the lower bulkhead screening plate mounting bolts. Drill two .25in. holes in the chassis immediately below, scrape the paint and underseal away, and secure these braids to the chassis with two nuts and bolts, the nuts being fitted from underneath the car.

Package No. 2: Remove the sparking plug leads and fit the suppressors. Cut the H.T. lead from coil to distributor and fit the 15 K ohm. in-line suppressor. Fit the two 1 mfd. condensers to the alternator earth terminal by their body clips and connect their leads to the main alternator terminal (brown cable). Fit the .25 mfd. condenser to a suitable bolt on the engine near the oil pressure sender unit and connect its lead to the sender unit.

Package No. 3: Fit the three similar earth braids so as to connect the two engine screening plates, using nuts and bolts in the three holes in the flange of each plate. Fit the other two braids, one between the centre hole in the bulkhead screening plate flange and the rear rocker cover bolt and the other between the air cleaner clamp and the rocker cover bolt.

Package No. 4: Fit the 11 in. (27.94 cm.) earth braid from a radiator fan mounting bolt to the chassis mounting bolt below. Fit the 15 in. (38.1 cm.) earth braid from a heater motor mounting bolt to the chassis mounting bolt below. Connect the aerial earth braid (see section on aerial) to the bolt on the end of the wiper motor and to the bottom left-hand corner of the heater by removing the screw at that point and replacing it by a longer one and a washer. Finally, connect the end of this braid to earth using one of the screws fixing the throttle cable bracket to the left side of the tunnel. The radio earth braid (see section on radio) should also be connected to earth at this point.

Package No. 5: Cut the R/LG and U/LG cables to the wiper motor and fit two-way bullet connectors so that the 1 mfd. capacitor can be plugged in between these cables as shown in Fig.1.

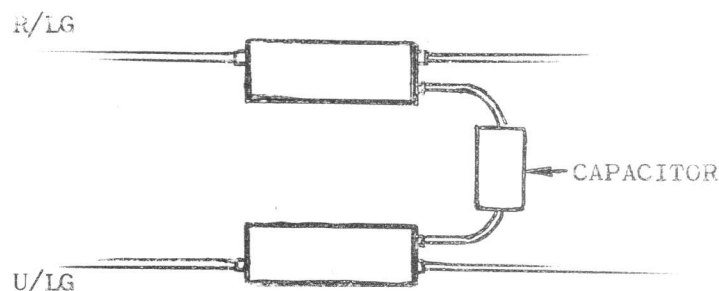

FIG 1

Remove the trim panel from the left-hand door. Fit two 1 mfd. capacitors, one between each of the feed cables to the window motor and the earth screw in the door. Suppression of the right-hand window motor is not necessary due to its distance from the aerial. Locate the 10 volt Voltage Stabiliser behind the facia. Fit two 1 mfd. capacitors, one between each of the I and B terminals and earth. Fit the 200 MH choke in the line from the I terminal to the instruments. Two types of voltage stabiliser have been used. The early one had a body earth, whilst the later one has a third terminal earth.

Aerial: Pull back the trim and felt from the inside of the left-hand front corner of the car interior. Cut a .438 in. hole in the front left-hand wing at such a position that the aerial tube will come just inside the car rather than in the wheel arch. Mount the aerial, fixing one end of the aerial earth braid from Package No. 4 of the suppression kit (see above) between the earthing bracket of the aerial and the car body, ensuring a good connection (see Fig.2).

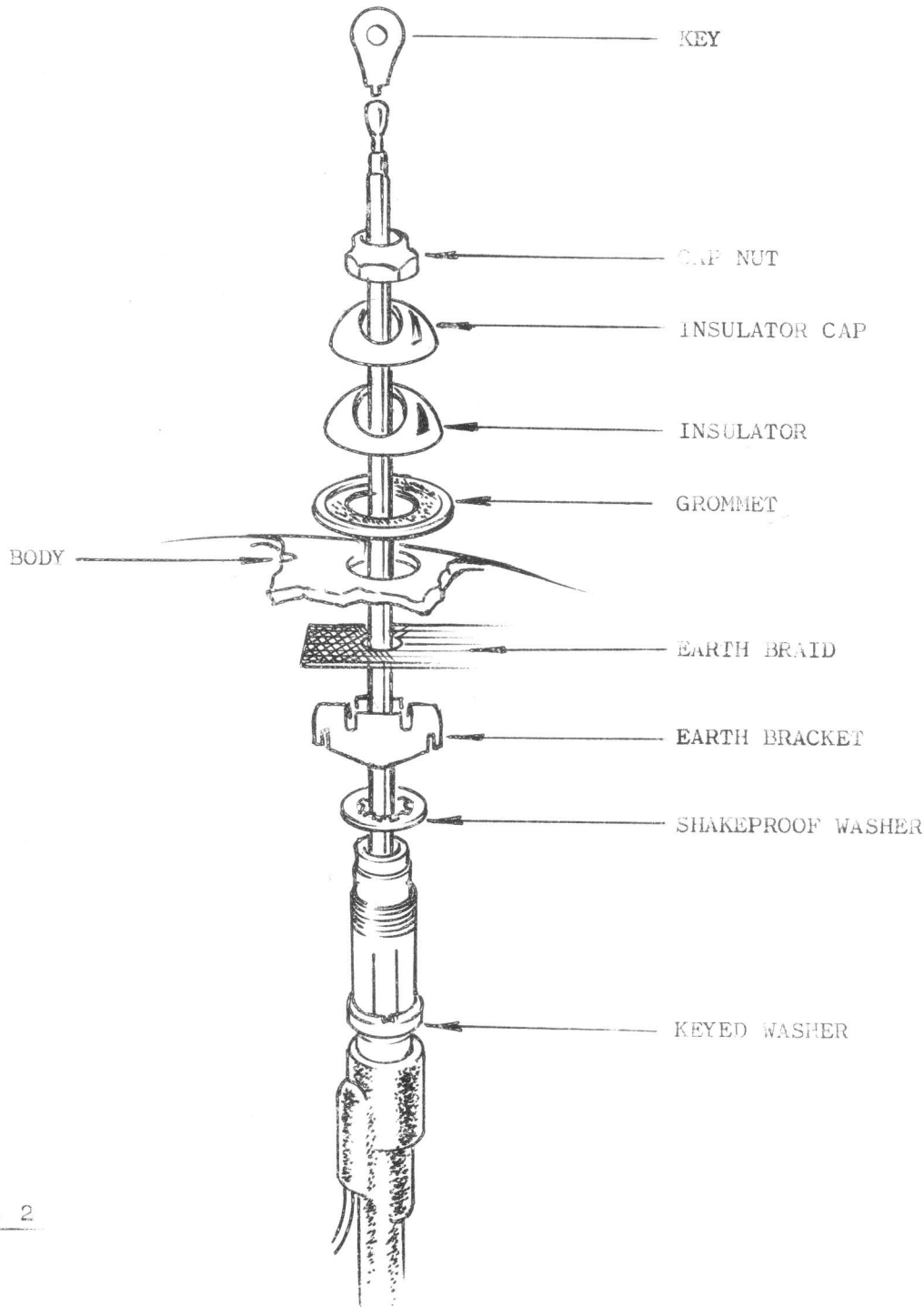

FIG. 2

Loudspeaker: Remove the trim panel from the door (left or right whichever preferred). At the lower front corner of the panel is an oval cutout in the fibreglass. Cut the trim to the same shape as this cutout. Making four holes in the trim as necessary, pass the speaker grille fixing studs through the panel. Mount the loudspeaker on the back of the panel on these studs using the four 4 BA nuts, plain washers and spring washers supplied in Package L 7. Connect the speaker to the leads in the door and replace the trim panel. In Series 1 cars the speaker is mounted in the rear bulkhead between the seats.

Radio: Remove the radio aperture blanking plate from the fascia panel. Remove the control knobs from the radio by pulling them off their spindles. Remove the hexagon nuts thus revealed and remove the tuning scale. Locate the loudspeaker lead behind the fascia and connect it to the radio. Connect also the aerial jumper lead and battery lead, inserting the fuse in the latter. Insert the radio into the aperture in the fascia and push it back so that it can be eased round to fit the two side fixing brackets as shown in Fig. 3, with the two small bolts and washers supplied in Package No. 5 of the kit.

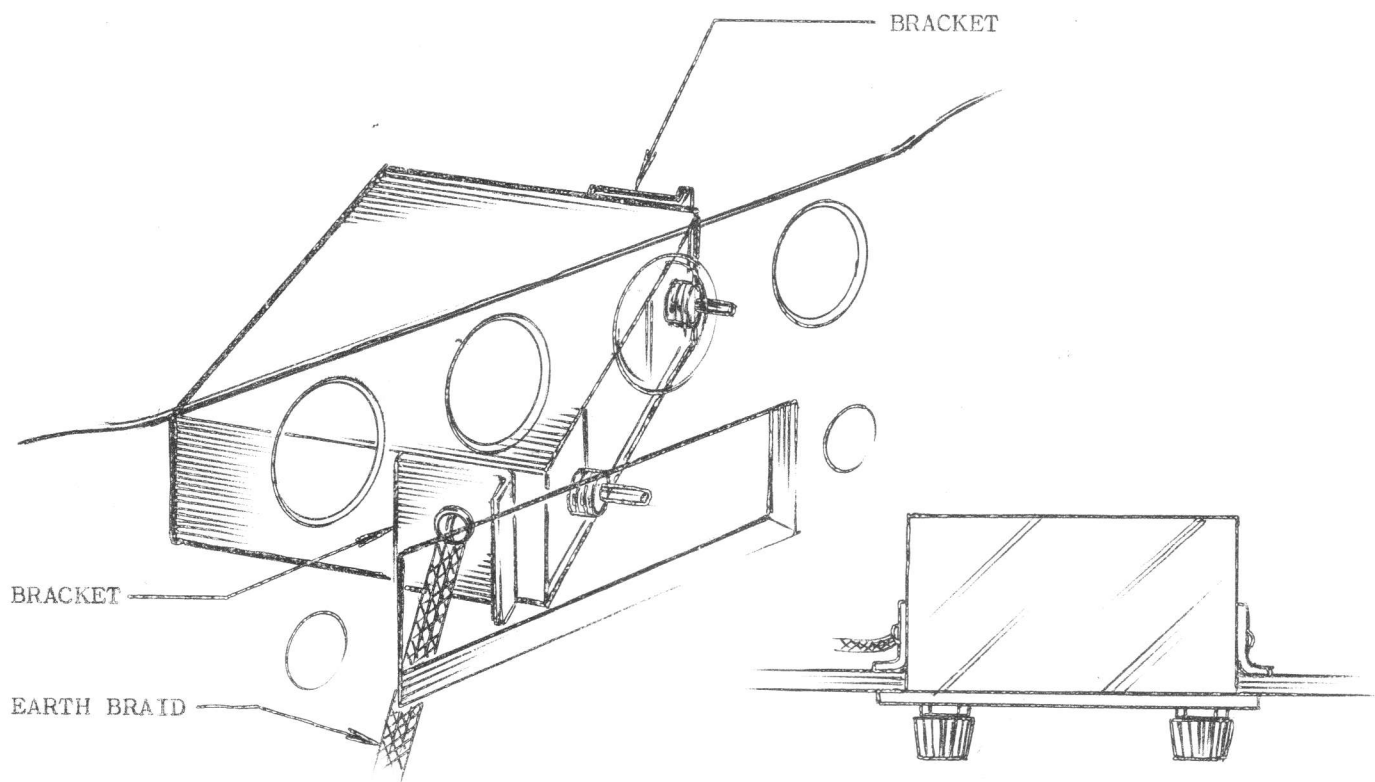

FIG. 3

Remember to connect the earth braid to the left-hand bracket - see Package No. 4. Having fitted these brackets, move the radio forward so that the front protrudes from the fascia. Place the chrome bezel from the fixing kit over the front, replace the tuning scale and replace the hexagon nuts and control knobs. Connect the battery lead to terminal 4 on the ignition switch and the jumper lead to the aerial lead.

Engine Mounting Blocks: It is recommended that the front engine mountings (Part No. 26 E 374) on all cars other than Federal be changed for those (Part No. 54 E 6000) used on Federal cars. This lowers the engine by approximately .5in. (12.7 mm.), thus increasing the clearance between the air cleaner and the upper engine screening plate. (See also Service Bulletin Class III 1969/27 (Non-Federal territories)).

Please amend your Lotus Labour Schedule (Part No. 36 T 328) on Page 50 (Accessories T), adding:-

'T - 123 Radio, Series 1 and 2 Europa - Install.'

and then, under the Europa column, the time:-

'8 hours'.